

Owner's Manual & Assembly Instructions

S001

Model No. CO1014-B **DG1014-A** **DK1014-A**
LX1014-B **RV1014-A** **TSC1014**
VS1014-B **VY1014** **WV1014-B**
YT1014-B
697.68604 **697.68630** **697.68756-C**

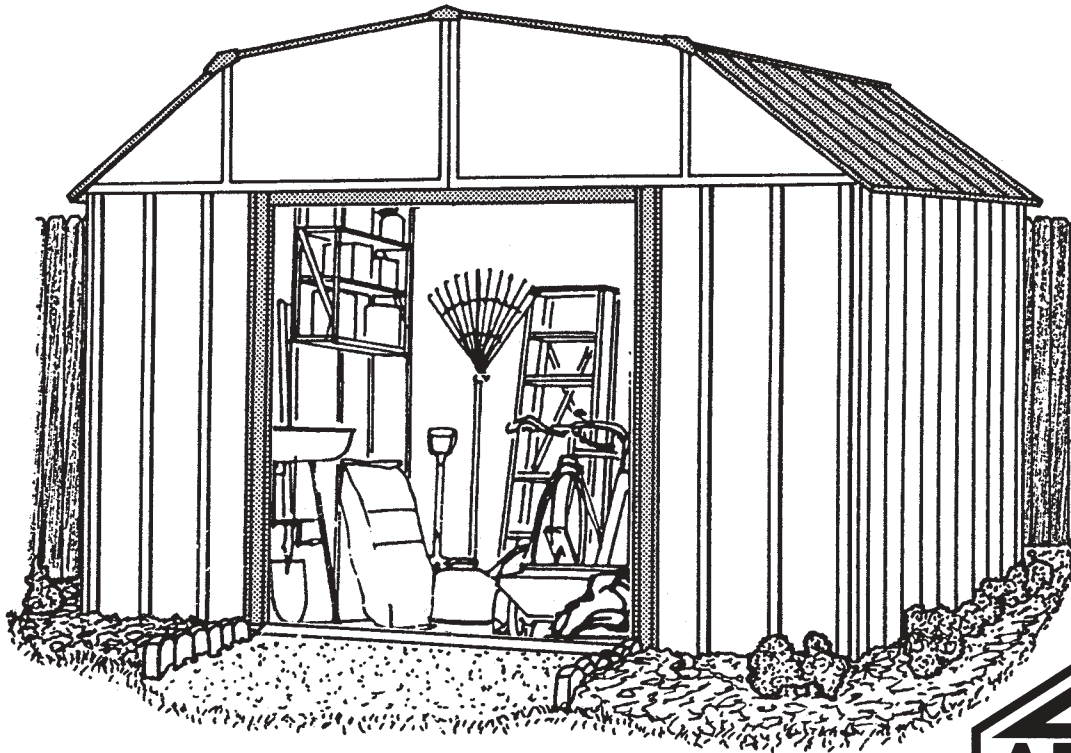

712730706

BUILDING DIMENSIONS * Size rounded off to the nearest foot



CAUTION: SOME PARTS HAVE SHARP EDGES. CARE MUST BE TAKEN WHEN HANDLING THE VARIOUS PIECES TO AVOID A MISHAP. FOR SAFETY SAKE, PLEASE READ SAFETY INFORMATION PROVIDED IN THIS MANUAL BEFORE BEGINNING CONSTRUCTION. WEAR GLOVES WHEN HANDLING METAL PARTS.

*Approx. Size	Foundation Size	Storage Area Sq. Ft. Cu. Ft.		Exterior Dimensions (Roof Edge to Roof Edge)			Interior Dimensions (Wall to Wall)			Door Opening	
				Width	Depth	Height	Width	Depth	Height	Width	Height
10' x 14'	121" x 160 1/4"	129	852	123 1/4"	162 3/4"	87 7/8"	118 1/4"	157 1/2"	86 5/8"	55 1/2"	60"
3,0m x 4,0m	307cm x 407cm	12,0m ²	24,1m ³	313cm	413cm	223cm	300cm	400cm	220cm	141cm	152cm

BEFORE YOU BEGIN....

A2

Owner's Manual

Before beginning construction, check local building codes regarding footings, location and other requirements. Study and understand this owner's manual.

Important information and helpful tips will make your construction easier and more enjoyable.

Assembly Instructions: Instructions are supplied in this manual and contain all appropriate information for your building model. Review all instructions before you begin, and during assembly, follow the step sequence carefully for correct results.

Foundation and Anchoring: Your storage building must be anchored to prevent wind damage. A foundation is also necessary as a base in order to construct a square and level building. Anchoring and foundation materials are not included with your building. We recommend the combined use of an **Arrow Floor Frame Kit** and an **Arrow Anchoring Kit** as an effective method of securing your building to the ground (Available by mail order or at your local dealer) or you may construct a foundation and anchoring system of your choice. Your assembly instructions provide information on a few methods commonly used to secure and level a storage building.

Parts and Parts List: Check to be sure that you have all the necessary parts for your building.

- All part numbers can be found on the parts. All of these numbers (before the -) must agree with the numbers on the parts list. The parts list is located on page 12.

- If you find that a part is missing, include the model number of your building and contact:

Arrow Group Industries, Inc. Customer Service Department
Route 50 East Breese, Illinois 62230
1-800-851-1085

- Separate contents of the carton by the part number while reviewing parts list. The first few steps show how to join related parts to make larger sub assemblies which will be used later.

- Familiarize yourself with the hardware and fasteners for easier use during construction. These are packaged within the carton. Note that extra fasteners have been supplied for your convenience.

PLAN AHEAD....

A3

Watch the Weather: Be sure the day you select to install your building is dry and calm. Do not attempt to assemble your building on a windy day. Be careful on wet or muddy ground.

Teamwork: Whenever possible, two or more people should work together to assemble your building. One person can position parts or panels while the other is able to handle the fasteners and the tools.

Tools and Materials: These are some basic tools and materials you will need for the construction of your building. Decide which method of anchoring and the type of foundation you wish to use in order to form a complete list of the materials you will need.

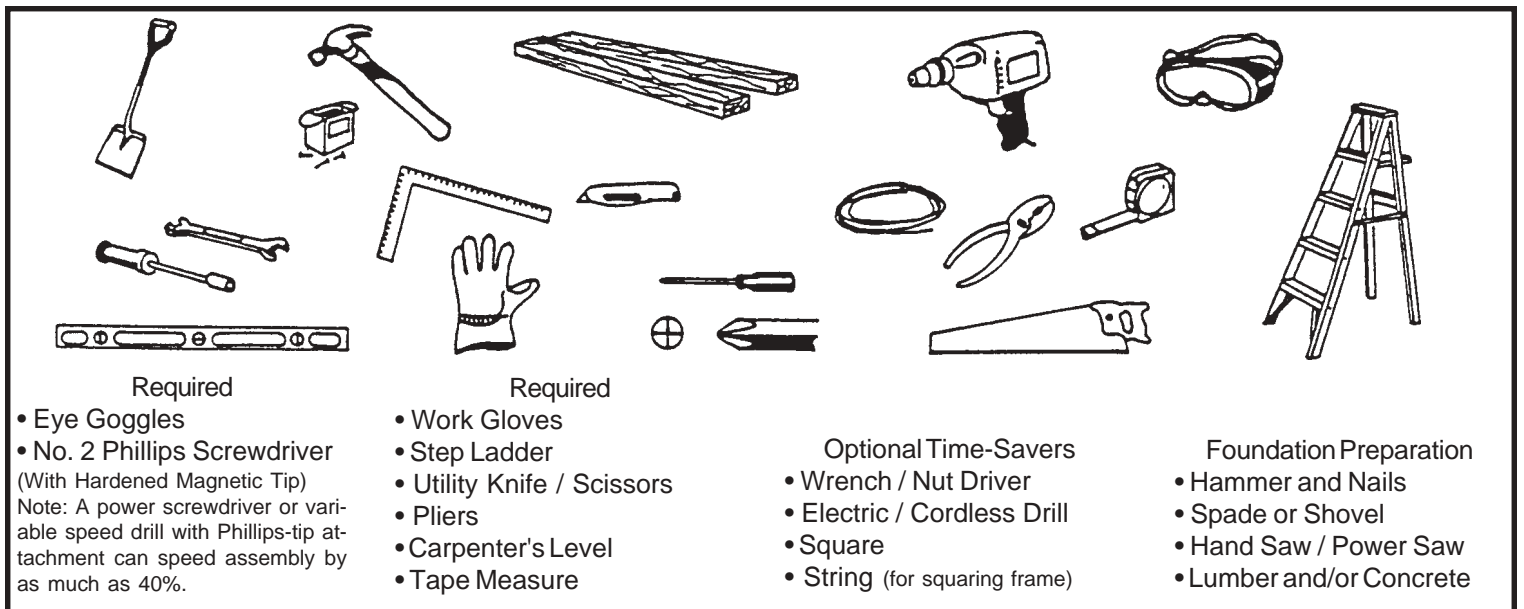

Selecting and Preparing Your Site: Before assembly, you will want to decide on a location for your building. The best location is a level area with good drainage.

- Allow enough working space for ease of moving parts into position during assembly. Be sure there will be enough space at entrance for doors to open fully and enough space around the building to be able to fasten the panel screws from the outside.

- Before you begin the first steps in assembling your parts, a foundation should be constructed and an anchoring system should be ready to use.

SAFETY FIRST...

A4

Safety precautions are important to follow throughout the construction of your building.

•Care must be taken when handling various pieces of your building since some contain sharp edges. Please wear work gloves, eye protection and long sleeves when assembling or performing any maintenance on your building.

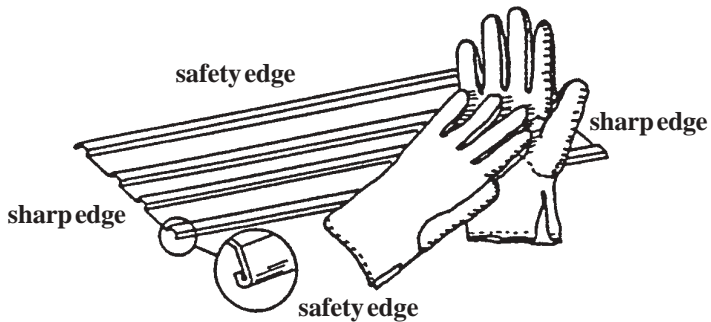

•Keep children and pets away from worksite to avoid distractions and any accidents which may occur.



•Never concentrate your total weight on the roof of the building. When using a step ladder make sure that it is fully open and on even ground before climbing on it.

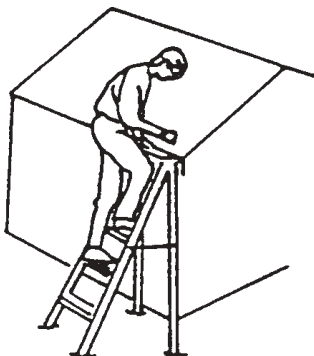

•Practice caution with the tools being used in the assembly of this building. Be familiar with the operation of all power tools.

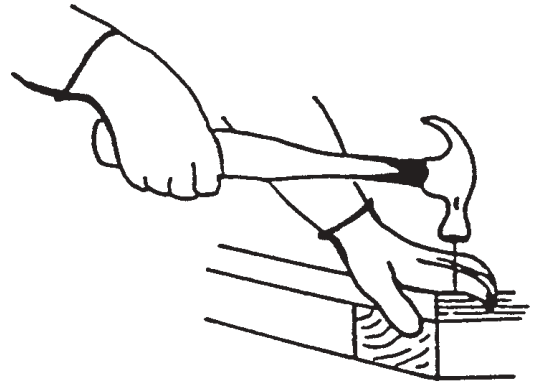

•Do not attempt to assemble the building if parts are missing because any building left partially assembled may be seriously damaged by light winds. Call 1-800-851-1085

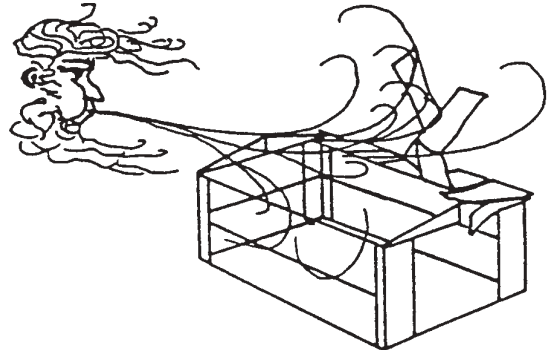

•Do not attempt to assemble the building on a windy day, because the large panels acting as a "sail", can be whipped about by the wind making construction difficult and unsafe.

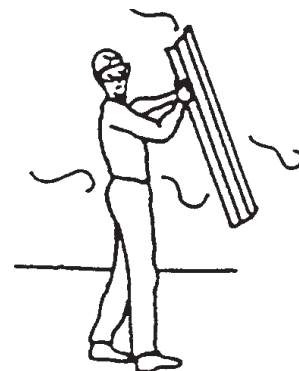

CARE & MAINTENANCE....

A5 Web

Finish: For long lasting finish, periodically clean and wax the exterior surface. Touch-up scratches as soon as you notice them on your unit. Immediately clean the area with a wire brush; wash it and apply touch-up paint per manufacturer's recommendation.

Roof: Keep roof clear of leaves and snow with long handled, soft-bristled broom. Heavy amounts of snow on roof can damage building making it unsafe to enter. In snow country, Roof Strengthening Kits are available for most Arrow Buildings for added protection against heavy snow accumulation.

Doors: Always keep the door tracks clear of dirt and other debris that prevent them from sliding easily. Lubricate door track annually with furniture polish or silicone spray. Keep doors closed and locked to prevent wind damage.

Fasteners: Use all washers supplied to protect against weather infiltration and to protect the metal from being scratched by screws. Regularly check your building for loose screws, bolts, nuts, etc. and retighten them as necessary.

Moisture: A plastic sheet (vapor barrier) placed under the entire floor area with good ventilation will reduce condensation.

Other Tips....

- Wash off inked part numbers on coated panels with soap and water.
- Silicone caulking may be used for watertight seals throughout the building.

Do not store swimming pool chemicals in your building. Combustibles and corrosives must be stored in air tight approved containers.

Keep this Owner's Manual and Assembly Instructions for future reference.

ACCESSORIES...

A6 WEB

ROOF STRENGTHENING (heavy snow load) KITS

Extra roof beams and gable braces designed for added protection against heavy snow accumulation. Increases the strength of your roof by 50%.

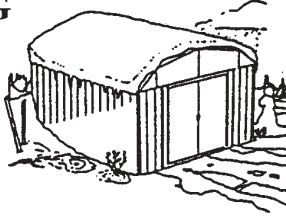

ANCHOR KITS

Model No. AK4

Anchor Kit contains heavy-duty steel augers, 60' (18m) of steel cable and 4 cable clamps. No digging or concrete pouring, just insert cable under roof, over roof beams, into augers and twist augers into the ground. For buildings larger than 10'x9', use 2 kits.

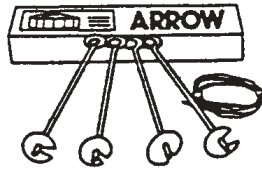

Model No. AK100

New concrete anchor system permits anchoring any size Arrow building directly to a concrete slab. Each kit contains heavy-duty, hot-dipped galvanized steel corner gussets and perimeter clips which fit over the floor frame and lag bolt into a concrete slab. Full assembly instructions and a 1/4" masonry drill bit are included.

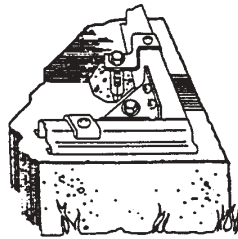

Model No. AK600

Earth Anchor Kit anchors any size Arrow building to the ground. Each kit contains heavy duty, hot-dipped galvanized steel corner gussets and 4 earth anchors.

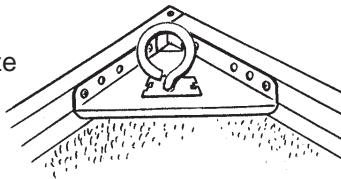

TOOL HANGING RACK

Model No. TH100

The perfect tool organizer. Twin 25 1/2" (65cm) steel channels plus five heavy-duty snap-in hangers and a small tool holder for screwdrivers, pliers, etc. Holders slide along channel for fully adjustable spacing. Great for garage, basement, or the back of any door. Fits all Arrow storage buildings.

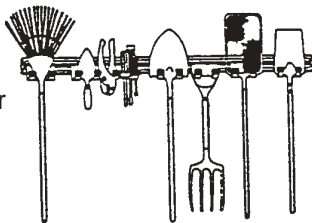

FLOOR FRAME KITS

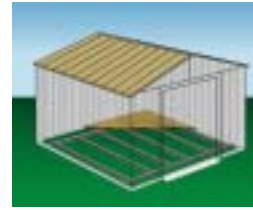

MODELS FB47410, FB5465, FB106-A
FB109-A and FB1014-A

A simple new floor frame system made of heavy-duty, hot-dipped galvanized steel. Use as foundation for plywood, sand or stone.

ATTIC KIT / WORKBENCH KIT

Heavy-duty galvanized steel bars that fit all 10' wide Arrow buildings. They install quickly and easily to help organize space and create more useable space as an attic or workbench. Will hold up to 250 lbs. (113kg) evenly distributed.



Model No.	Fits	Shipping Weight
AT101	10' Long, 250 lb. (113kg) load+ Fits all Arrow 10' wide buildings.	16 lbs. (7kg)

Must be drilled for use as workbench in Estator.
+ Even weight distribution.

SHELF UNITS

Heavy-duty, galvanized steel shelf units help organize storage space. They easily mount on the wall or sit on the floor. Fits all Arrow buildings.*

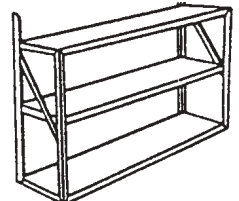
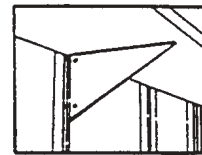
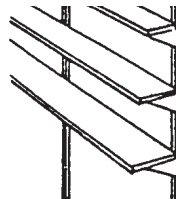

Model No. SS404

- Makes 8" to 12" (20-30cm) wide shelves in any length.
- Brackets, braces, hardware included. Lumber is not included.

Model No. SS900-A

- Grey color
- 3 shelves
- Holds up to 85 lbs. (38kg) (even weight distribution)

* Some drilling required to fit buildings without mid-wall bracing.

THIS
PAGE
WAS
LEFT
BLANK
INTENTIONALLY

THIS
PAGE
WAS
LEFT
BLANK
INTENTIONALLY

Foundation

F09

The Foundation For Your Building

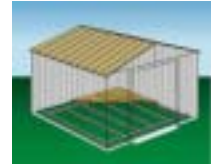

OPTION 1: ARROW FLOOR FOUNDATION KIT: (Order No. FB1014-A or 68387-A)

Arrow has the best base for your building in this simple kit. It keeps stored items above the ground.

This foundation should be used with one of the following:

A. To support a plywood deck **B.** To be filled with sand. We recommend the combined use of **1. an ARROW FLOOR FOUNDATION KIT** and **2. an ARROW ANCHORING KIT** as an effective method of securing the building to the ground. **Allow 1 - 2 hours for construction.**

OPTION 2: Wood Platform

If you decide to build your own foundation, be sure to select the appropriate materials.

These are the recommended materials for your foundation:

- 2 x 4's (5cm x 10cm) Pressure Treated Lumber
- 5/8" (1,5cm) 4 x 8 (122cm x 244cm) Plywood-exterior grade
- 10 & 4 penny Galvanized Nails
- Concrete Blocks (optional)

The platform should be level and flat (free of bumps, ridges etc.) to provide good support for the building. The necessary materials may be obtained from your local lumber yard.

To construct the foundation follow instructions and diagram.

Construct frame (using 10 penny galvanized nails)

Measure 16"/24" (40,6cm/61cm) sections to construct inside frame (see diagram)

Secure plywood to frame (using 4 penny galvanized nails)

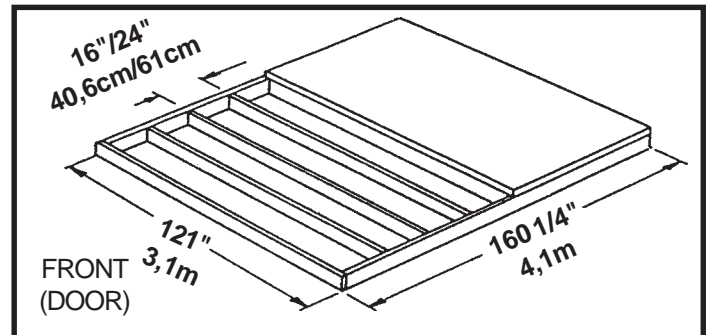

Allow 6 - 7 hours for construction.

Note: Platform/Slab will extend 9/16" (1,4cm) beyond floor frame on all four sides. Seal this 9/16" of wood with a roofing cement (not included), or bevel this 9/16" of concrete when pouring, for good water drainage.

OPTION 3: Concrete Slab

The slab should be at least 3" to 4" (8-10cm) thick. It must be level and flat to provide good support for the frame.

The following are the recommended materials for your foundation.

- 1 x 4's (2,5cm x 10cm) (will be removed once the concrete cures)
- Concrete
- Sheet of 6 mil plastic
- We recommend for a proper strength concrete to use a mix of:
1 part cement ● 3 parts pea sized gravel ● 2 1/2 parts clean sand

Prepare the Site/Construct a Foundation

1. Dig a square, 6" (15cm) deep into the ground (remove grass).
2. Fill up to 4" (10cm) in the square with gravel and tamp firm.
3. Cover gravel with a sheet of 6 mil plastic.
4. Construct a wood frame using four planks of 1x4 (2,5cm x 10cm) lumber.
5. Pour in concrete to fill in the hole and the frame giving a total of 4" (8-10cm) thick concrete. Be sure surface is level.

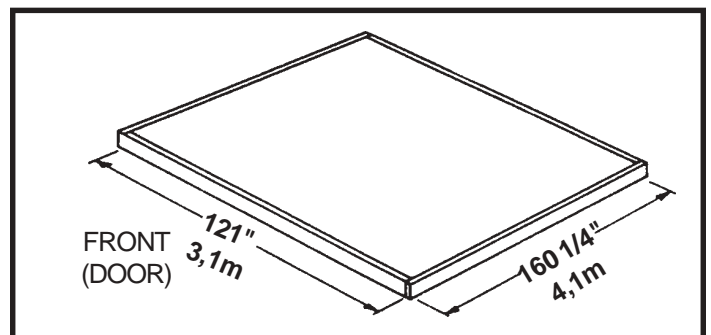

Note: Finished Slab dimensions, with lumber removed.

Allow 3 - 5 hours for construction and a week for concrete curing time.

Anchoring

A10

Anchoring Down The Building

It is important that the entire floor frame be anchored after the building is erected.

Below are recommended ways of anchoring.

Arrow Anchoring Kit: (Model No. AK4 or 60298)

Recommended for use with **any** suggested **base**.

Contains: 4 Anchors with Cable, Clamps and installation instruction.

Anchoring into Wood/Post:

Use 1/4" Wood Screws. There are 1/4" (0,63cm) dia. holes provided in the frames for proper anchoring.

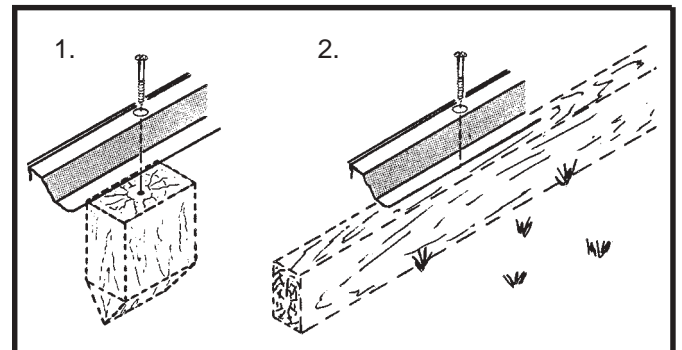
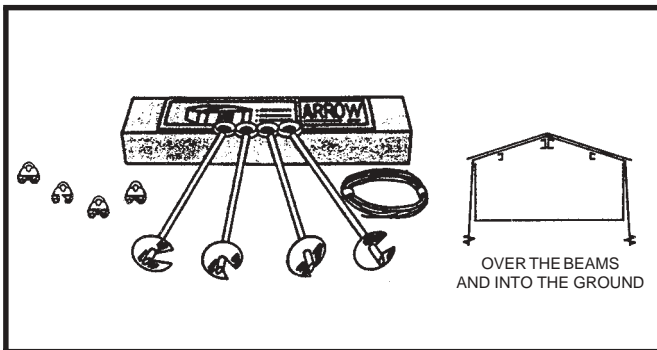

Arrow Anchoring Kit: (Model No. AK100 or 68383)

Recommended for use with the **concrete** foundation.

Contains: Corner gussets, perimeter clips, hardware, 1/4" masonry drill bit and installation instruction.

Anchoring into Concrete:

1. For poured concrete slab or footing or patio blocks: Use 1/4" x 2" Lag Screws.

2. For Anchor Post of Concrete poured after building is erected: Use 1/4" x 6" Lag Screws.

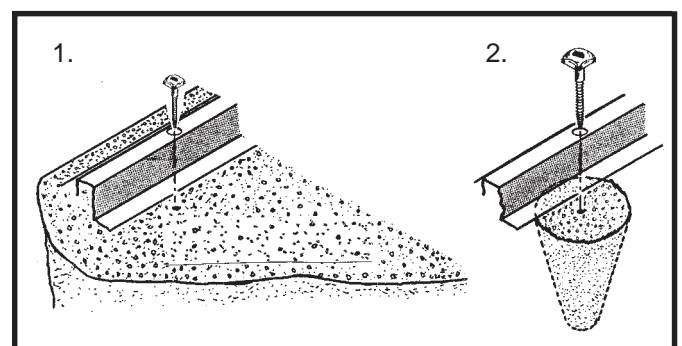
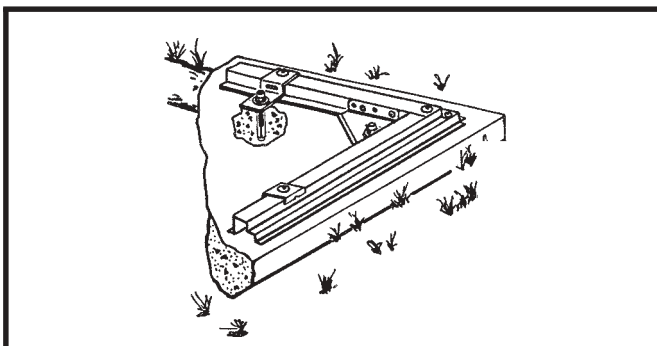

Hardware

SO11

Remove from bag of screws
and save for the last step



65103
#8-32 Hex Nut (222)



65900A
#10Bx1/2" Black Screw (4)
(Packed with Screws)



65923
#8-32x3/8" Bolt (222)



65004
#8Ax5/16" Screw (446)

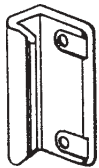

66045
Handle (2)

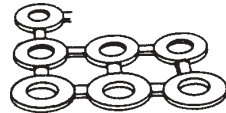

66646
Washer (499)
(13 sheets of 40)



65109
#8-32 Acorn Nut (4)
(Packed with Screws)

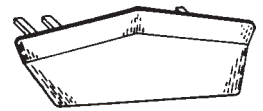

67468
Peak Cap (6)
(Arrow Logo)

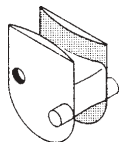

66242
Door Slide (4)

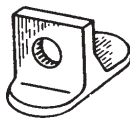

66382
Lower Door Guide (4)

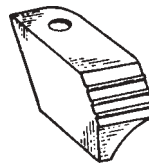

66183
Roof Trim Cap
(2 right & 2 left)

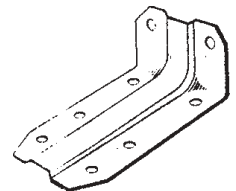

6228
Track Support (2)

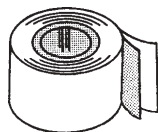

67545 21'
Weather Stripping (1)

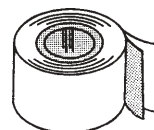

67293 10'
Weather Stripping (1)

Parts List

S012

Parts In Carton One

Assembly Key No.	Part Number	Part Description	Quantity In Carton	Check List
1	3719	Door Handle Brace	2	
2	9373	Front Wall Panel	2	
3	6020	Corner Panel	4	
4	6108	Large Right Gable	2	
5	6109	Large Left Gable	2	
6	6114	Small Right Gable	2	
7	6115	Small Left Gable	2	
8	6188	Right Roof Panel	2	
9	6189	Left Roof Panel	2	
10	6264	Horizontal Door Brace	4	
11	6278	Vertical Door Brace	2	
12	6515	Wall Panel	12	
13	6538	Roof Panel	8	
14	8538	Right Door	1	
15	8539	Left Door	1	
16	9369	Door Jamb	2	
17	67521	Edge Trim	2	
18	6015	Side Roof Trim	2	
19	6403	Door Track Splice	1	
20	6797	Ridge Cap	6	
21	6869	Ridge Cap	3	
22	6892	Right Side Roof Trim	2	
23	6893	Left Side Roof Trim	2	
24	9366	Door Track	2	

Parts In Carton Two

Assembly Key No.	Part Number	Part Description	Quantity In Carton	Check List
25	5986	Rear Wall Angle	2	
26	10389	Rear Wall Channel	2	
27	10388	Side Wall Channel	4	
28	9365	Front Wall Channel	2	
29	6085	Roof Beam Bracket	4	
30	6227	Roof Beam Brace	2	
31	10386	Roof Beam	8	
32	6636	Gable Brace	2	
33	10391	Side Wall Angle	4	
34	8936	Rear Floor Frame	2	
35	10387	Side Floor Frame	4	
36	9367	Front Floor Frame	2	
37	8934	Ramp	1	

Assembly by Key No.

SO13

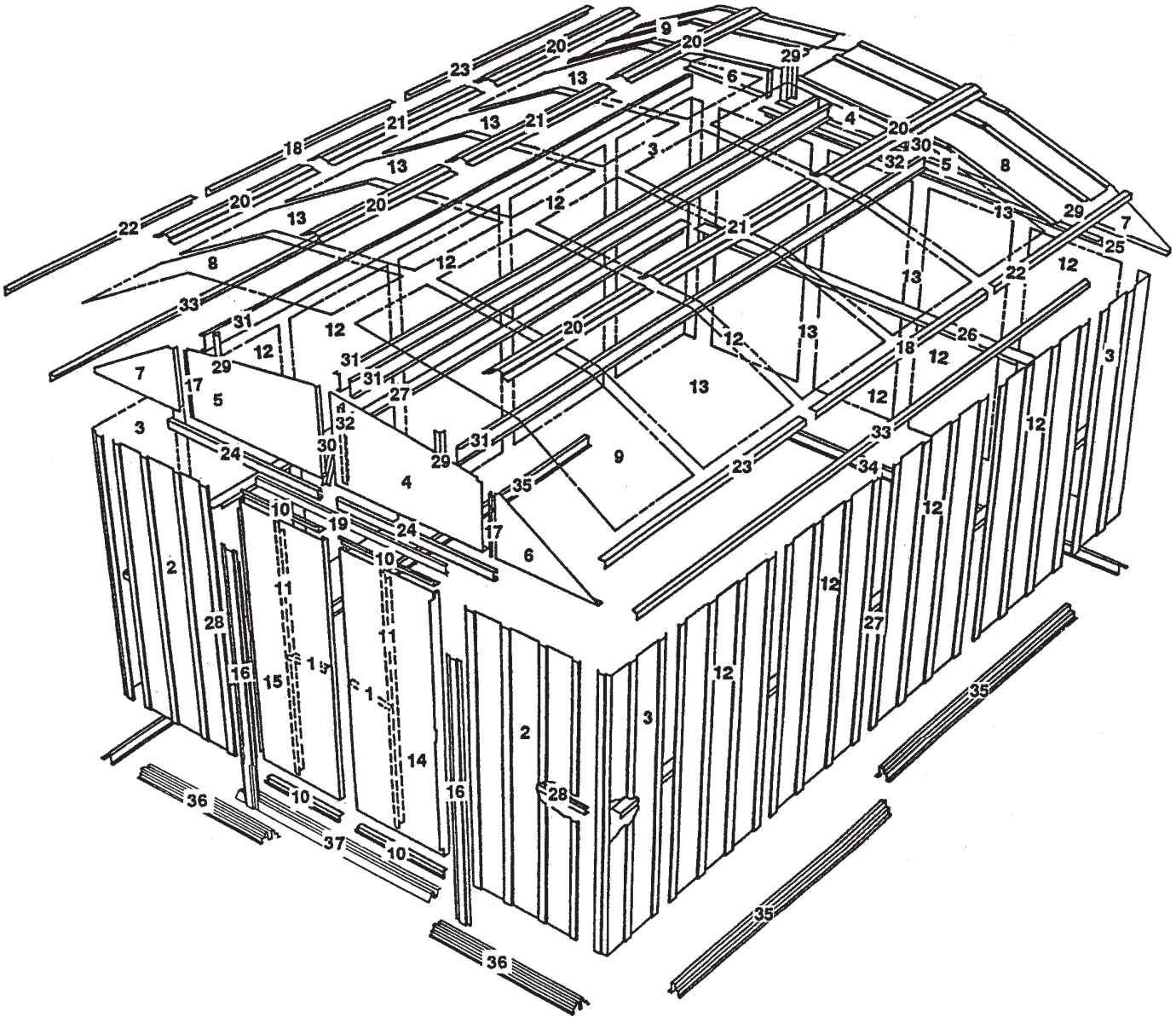

Step 1

SO14

● Parts Needed For ● Floor Frame Assemblies

- 8934 Ramp (1)
- 9367 Front Floor Frame (2)
- 8936 Rear Floor Frame (2)
- 10387 Side Floor Frame (4)

The front floor frame is made up of three pieces. The side floor frames and the rear floor frame are made up of two pieces. The holes in these pieces will align when the pieces are positioned with correct amount of overlap. The illustrations below show the proper overall length for the sides, rear and front. Proceed as follows:

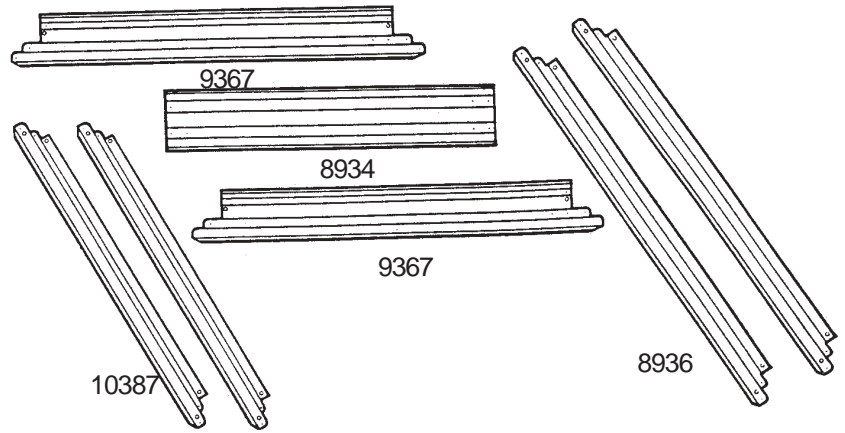

1 Place the **front floor frames** as shown. Center the **ramp**, with drain holes facing outside, on top of the two front floor frames. Join the frames by inserting eight screws.

STEP
1

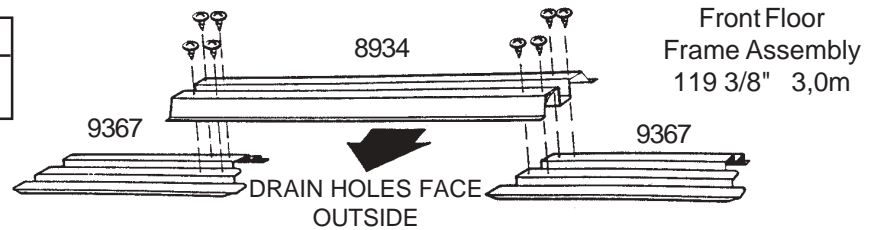

2 Overlap the **side floor frames** and the **rear floor frames** as shown. The holes in these pieces will align when the pieces are positioned with correct amount of overlap. See the illustrations below for the proper overall length of the side and rear floor frames. Join the frames by inserting four/five bolts into each frame set as shown.

STEP
2

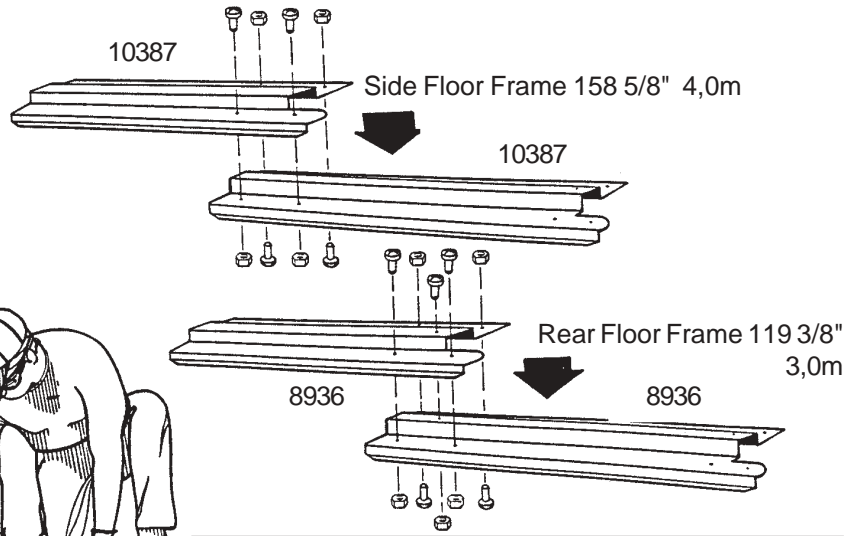

3 Double check the length of each and set these pieces aside for later use.

STEP
3

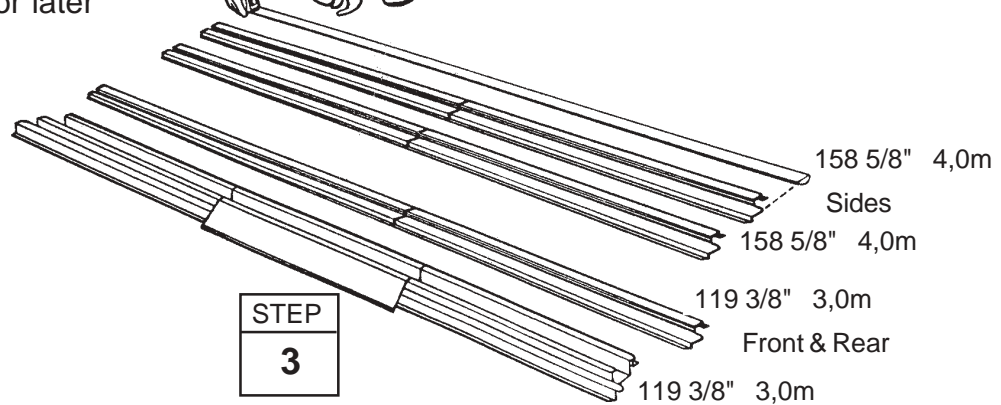

Step 2

SO15

● Parts Needed For ● Frame Assemblies

- 5986 Rear Wall Angle (2)
- 10389 Rear Wall Channel (2)
- 10388 Side Wall Channel (4)
- 10391 Side Wall Angle (4)

The main frame pieces reinforce the walls. These pieces will later be installed in the center and at the top edge of the side walls and the rear wall. Proceed as follows:

1 Overlap the **rear wall channel** pieces as shown in the figure and fasten the two pieces together with *eight bolts* as shown.

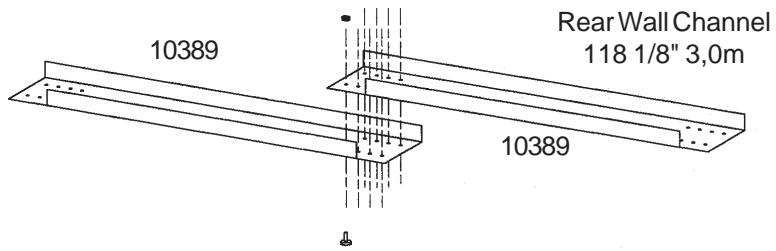

2 Make two **side wall channels** by overlapping the side wall channel pieces as shown. Fasten each set together with *eight bolts* as shown.

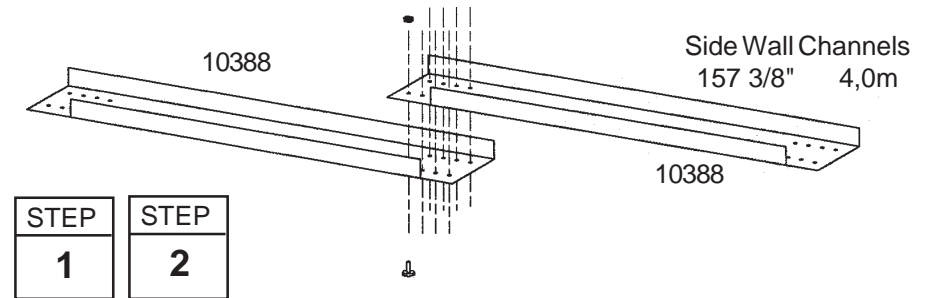

3 Overlap the **rear wall angle** pieces as shown in the figure and fasten them together with *one bolt in the center hole*.

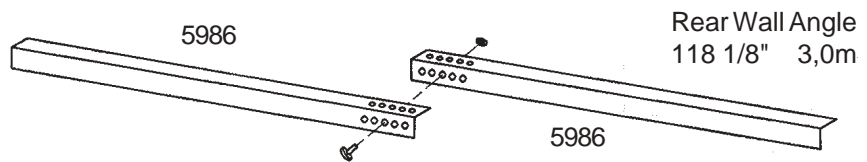

4 Make two **side wall angles** by overlapping the side wall angle pieces as shown. Fasten each set together with *one bolt thru the second large hole from the end of each part*.

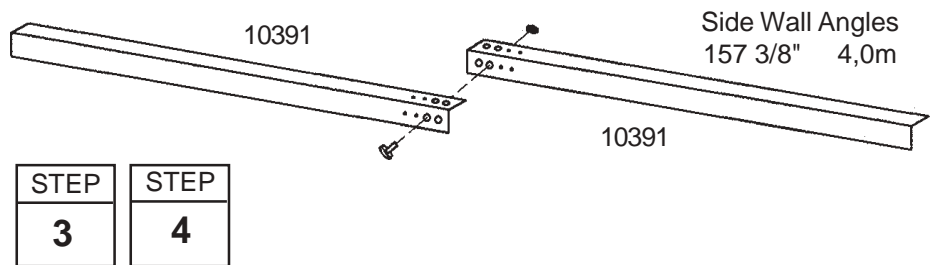

5 Set the assemblies aside. You will use them later.

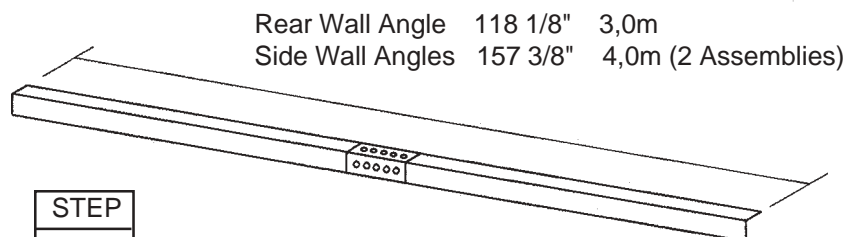
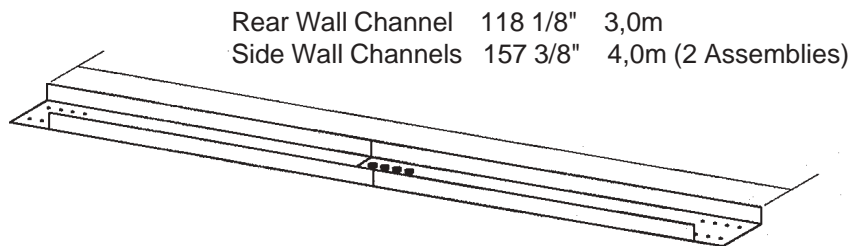

Step 3

SO16

● Parts Needed For ● Roof Beam Assemblies

● 10386 Roof Beam (8)

The roof beams join the two gables and support the roof panels. The main roof beam is made up of four pieces overlapped back to back at the center. The left and right roof beam assemblies are made up of two pieces. **Hint:** These pieces are force-fitted, so you may have to press hard to join them together.

1 Place the end of one roof beam inside a second roof beam so that the six holes in each piece align. Make four sets of roof beams by repeating this procedure. ***Do not insert bolts yet.***

2 Take two of the pressed-together roof beams and join them as shown to form the main roof beam assembly. Hold the assembly together and fasten with 14 bolts. Build ***only one*** Doubled Beam Assembly.

3 Fasten the other two pressed-together roof beams with eight bolts to make the left and right roof beam assemblies.

4 Set these pieces aside for later assembly.

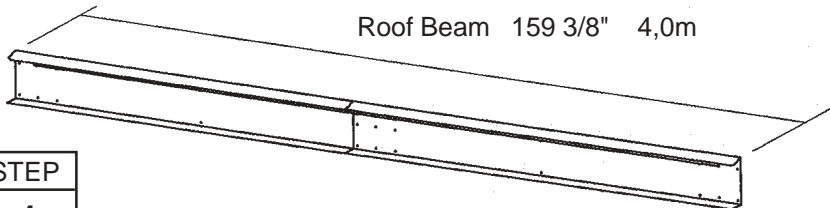
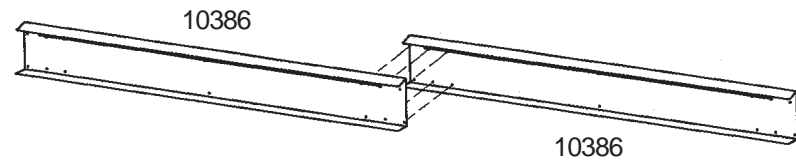

STEP
1

STEP
2

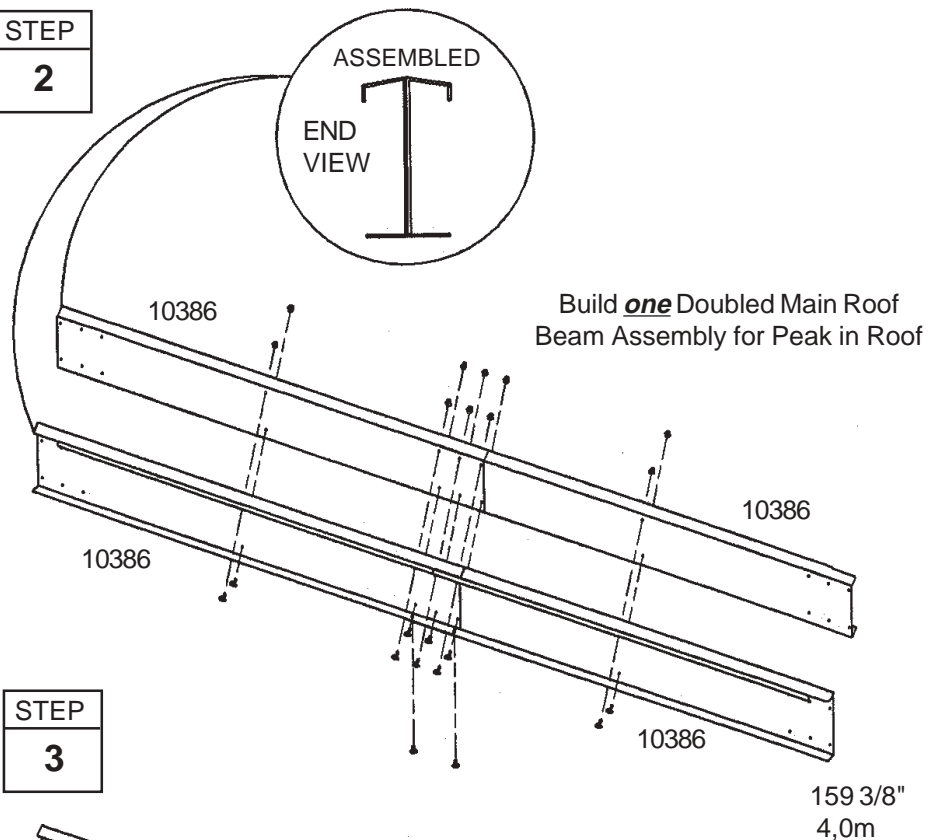

STEP
3

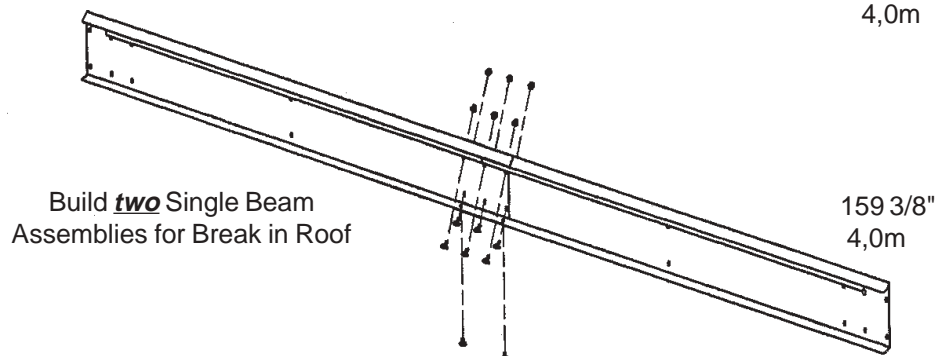

Step 4

SO17

● Parts Needed For ● Door Track Assembly

- 6403 Door Track Splice (1)
- 9366 Door Track (2)

The door track assembly supports the sliding doors and reinforces the front wall. It is made up of three pieces.

1 Using the **door track splice**, (painted), join the **door track** (galvanized) pieces end-to-end as shown.

2 Insert four screws *from the underside only*.

Hint: The holes in the top side of the door track assembly are for fastening the gable to the top of the front wall in a later step.

NOTE:

Door Track Splice (painted part)

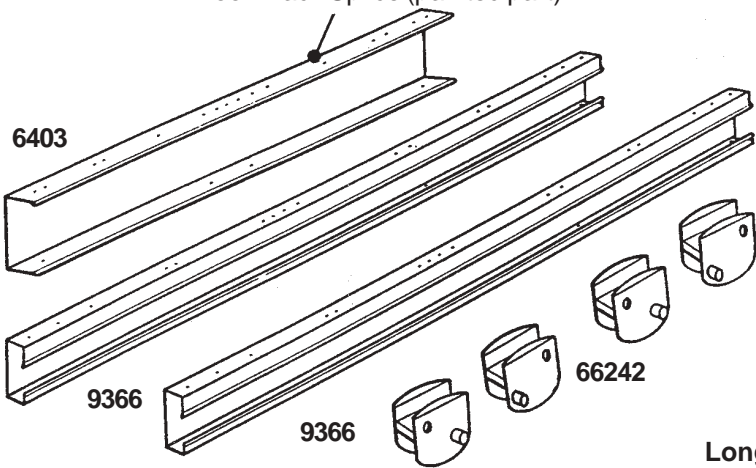

STEP
1

STEP
2

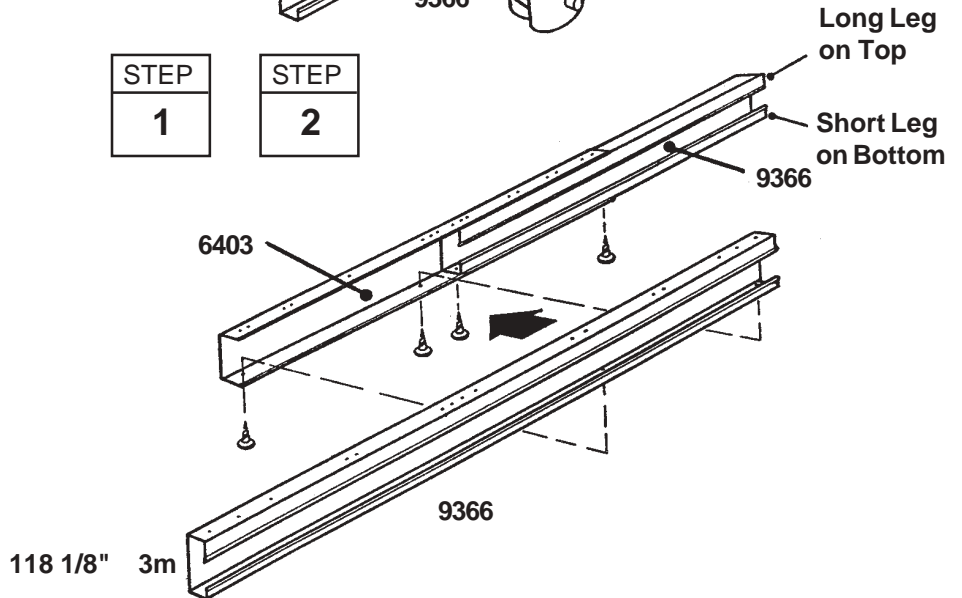

3 Position **door slides** onto the legs, from the end of door track assembly, as shown in the end view. **NOTE:** Flat side on top, pins and holes **must** be oriented as shown.

4 Set this piece aside for later use.

STEP
3

STEP
4

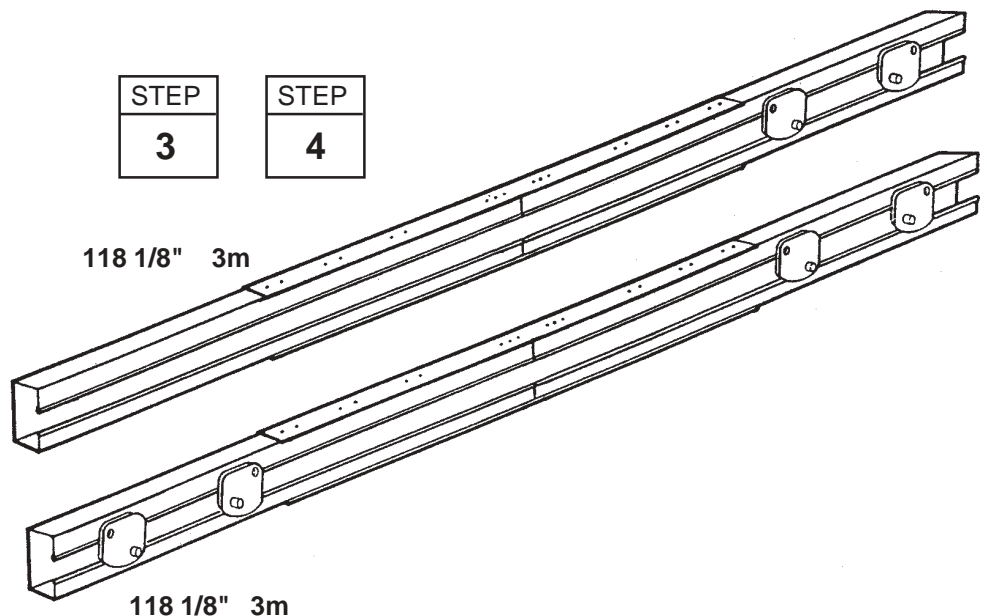

END VIEW

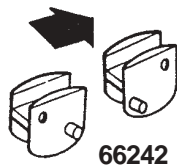

66242

Step 5

SO18

● Parts Needed For ● Floor Frame

- Front Floor Assembly (1)
- Side Floor Assembly (2)
- Rear Floor Assembly (1)

1 Place the floor frame pieces that you assembled earlier on the foundation. Assemble the four corners of the floor frame using two screws at each corner as shown. At the front corners fasten bolts through from the bottom with nuts on top.

STEP
1

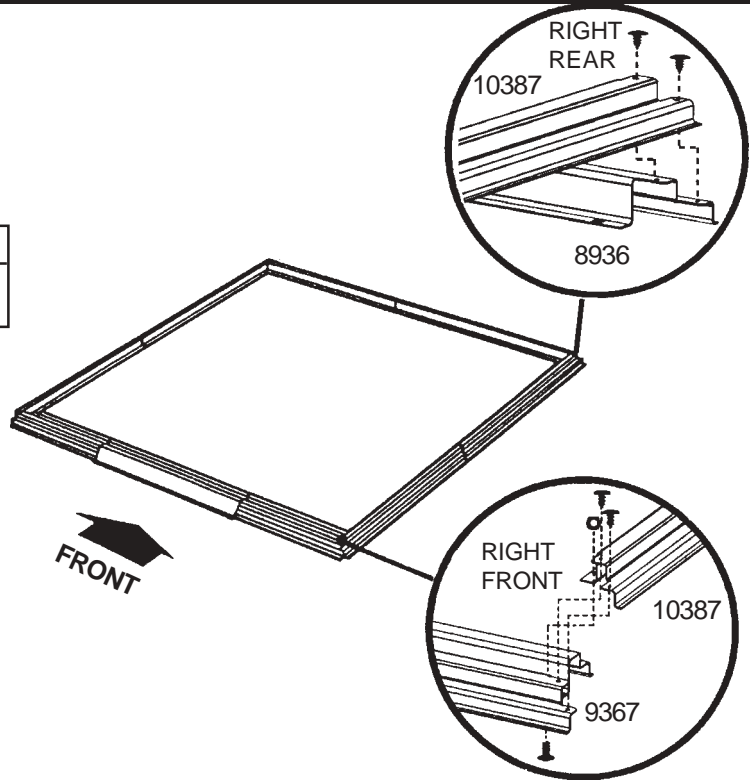

2 Measure the floor frame diagonally. When the diagonal measurements are equal, the floor frame is square.

When Diagonal Measurements are Equal the Floor Frame is Square.

NOTE
If using a wood platform or concrete slab do not fasten the floor frames to your base at this time. You will anchor the building after it is erected.

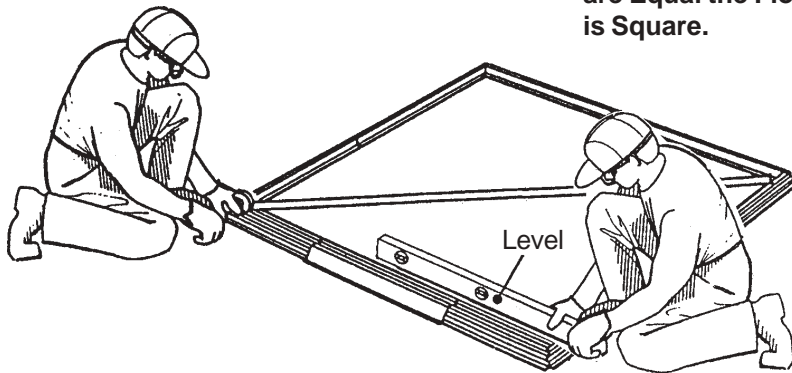

NOTE
If you have purchased a Floor Foundation Kit you need to install it at this time.

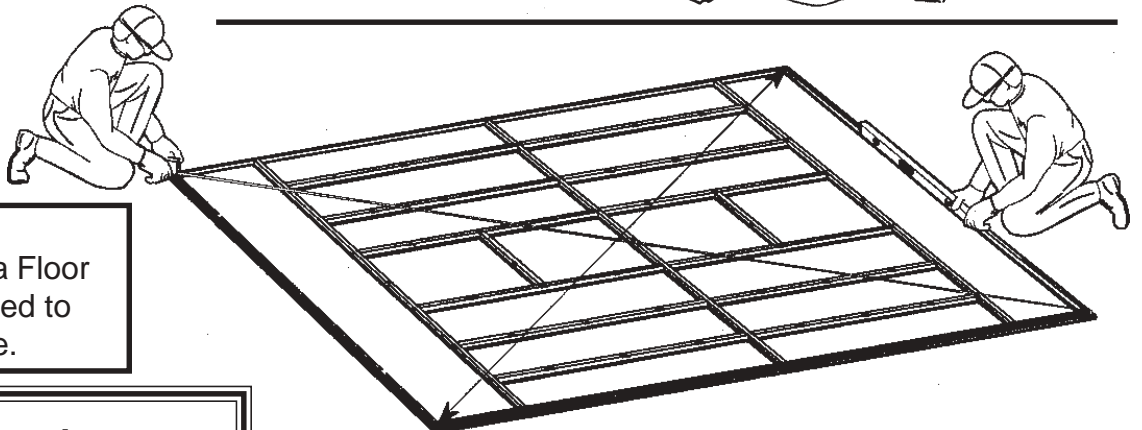

The floor frame *must be square and level* or holes will not align.

Step 6

S019

● Parts Needed For ● Corners

- 6515 Wall Panel (2)
- 9373 Front Wall Panel (2)
- 6020 Corner Panel (4)

NOTE

The remainder of the building assembly requires many hours and more than one person. Do not continue beyond this point if you do not have enough time to complete the assembly today. A partially assembled building can be severely damaged by light winds.

Each screw and bolt in the wall requires a washer.

1 Position a **corner panel** at the corner of the floor frame as shown. The widest part of each corner panel must be placed along the side of the building for all four corners. Fasten the corner panel to the floor frame with one screw.

Support the corner panel with a step ladder until a wall panel is attached.

2 Attach the **front wall panels** to the front corner panels, as shown. A small gap will exist between front wall panel and ramp.

3 Attach the **wall panels** to the rear corner panels, as shown.

NOTE

Be careful to install the correct panel in each position as shown

4 Double-check the part numbers of the wall panels, before proceeding.

The floor frame *must be square and level* or holes will not align.

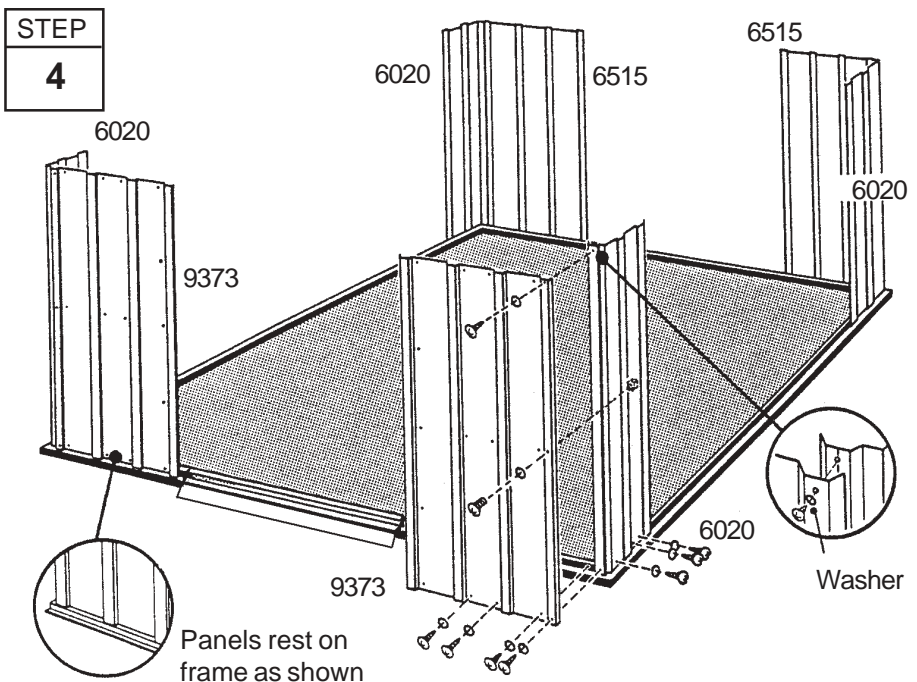
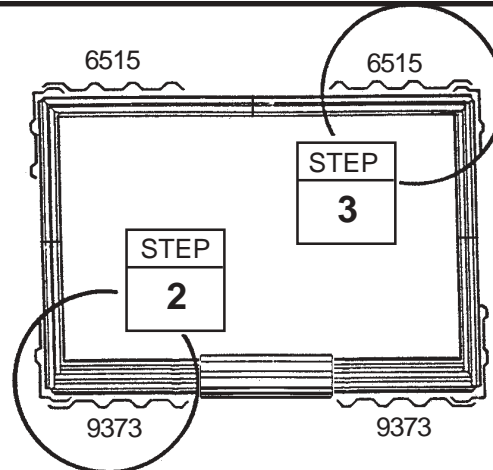
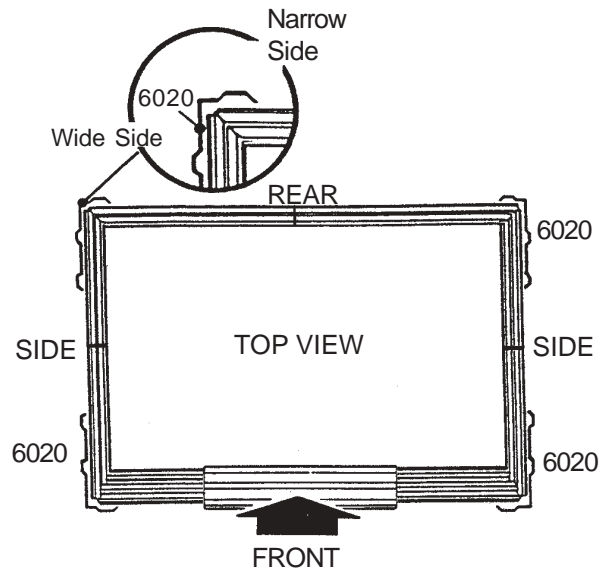

Step 7

SO20

● Parts Needed For ● Mid Frames

- Rear Wall Channel Assembly (1)
- Side Wall Channel Assembly (2)

The mid frame pieces give rigidity to the side and rear walls.

1 Fasten the **rear wall channel** across the middle of the rear wall using screws.

2 Fasten the **side wall channels** across the middle of the side panels using screws. Fasten overlaps in rear corners with bolts and nuts, at two locations. See the figure.

NOTE

The wall channels behind the front wall panels will be installed in a later step.

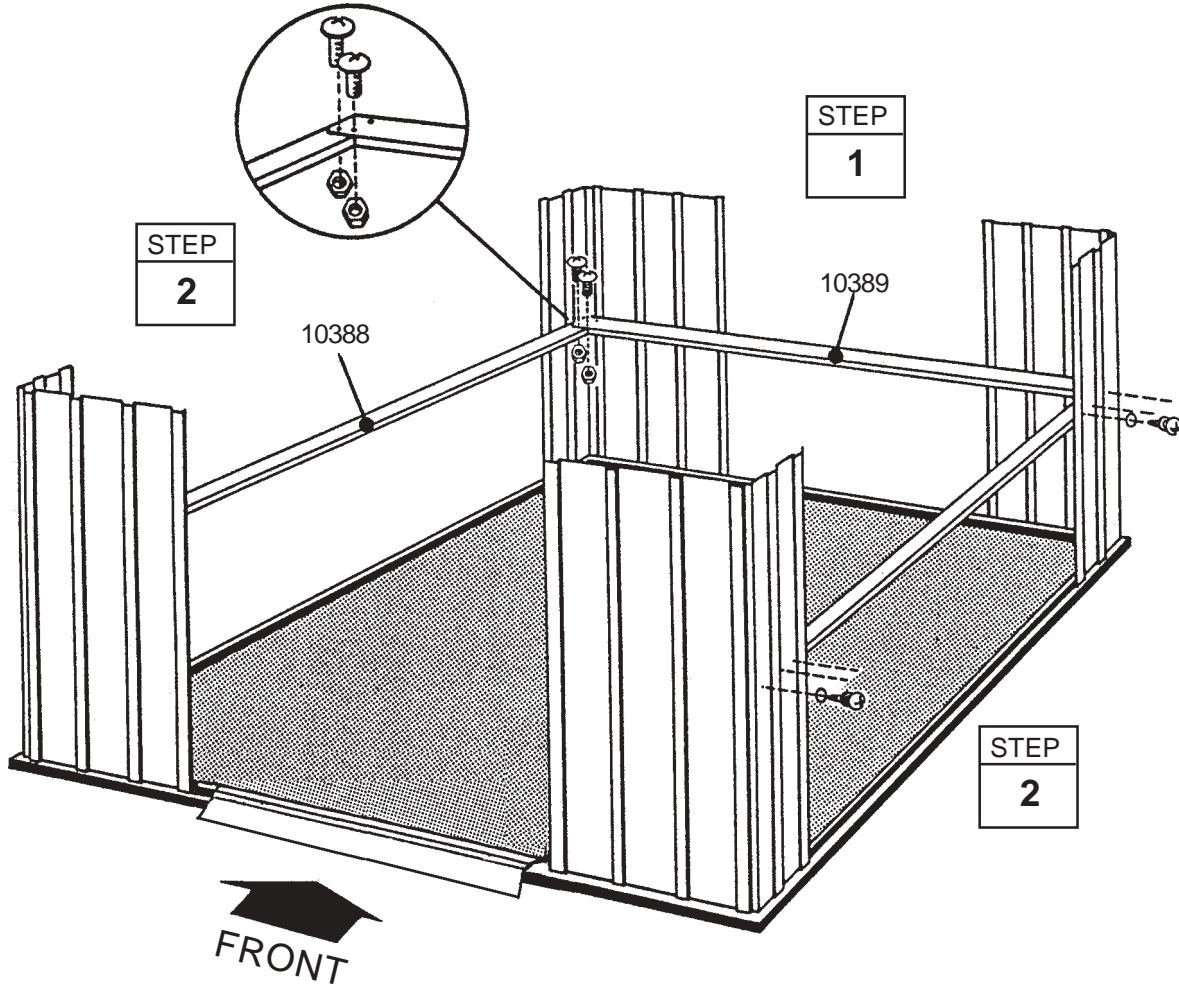

Step 8

S021

● Parts Needed For ● Top Frames

- Door Track Assembly (1)
- Rear Wall Angle Assembly (1)
- Side Wall Angle Assembly (2)

The top frame pieces give rigidity to the walls and provide a surface for attaching the gables which support the roof.

1 Fasten the **rear wall angle** across the inside top of the rear wall using screws.

2 Fasten the **side wall angles** across the inside top of the side panels using screws. Side wall angles must overlap rear wall angle in corners.

3 Fasten the **door track assembly** (holes on top) across the top of the front wall panels using screws. See the figure.

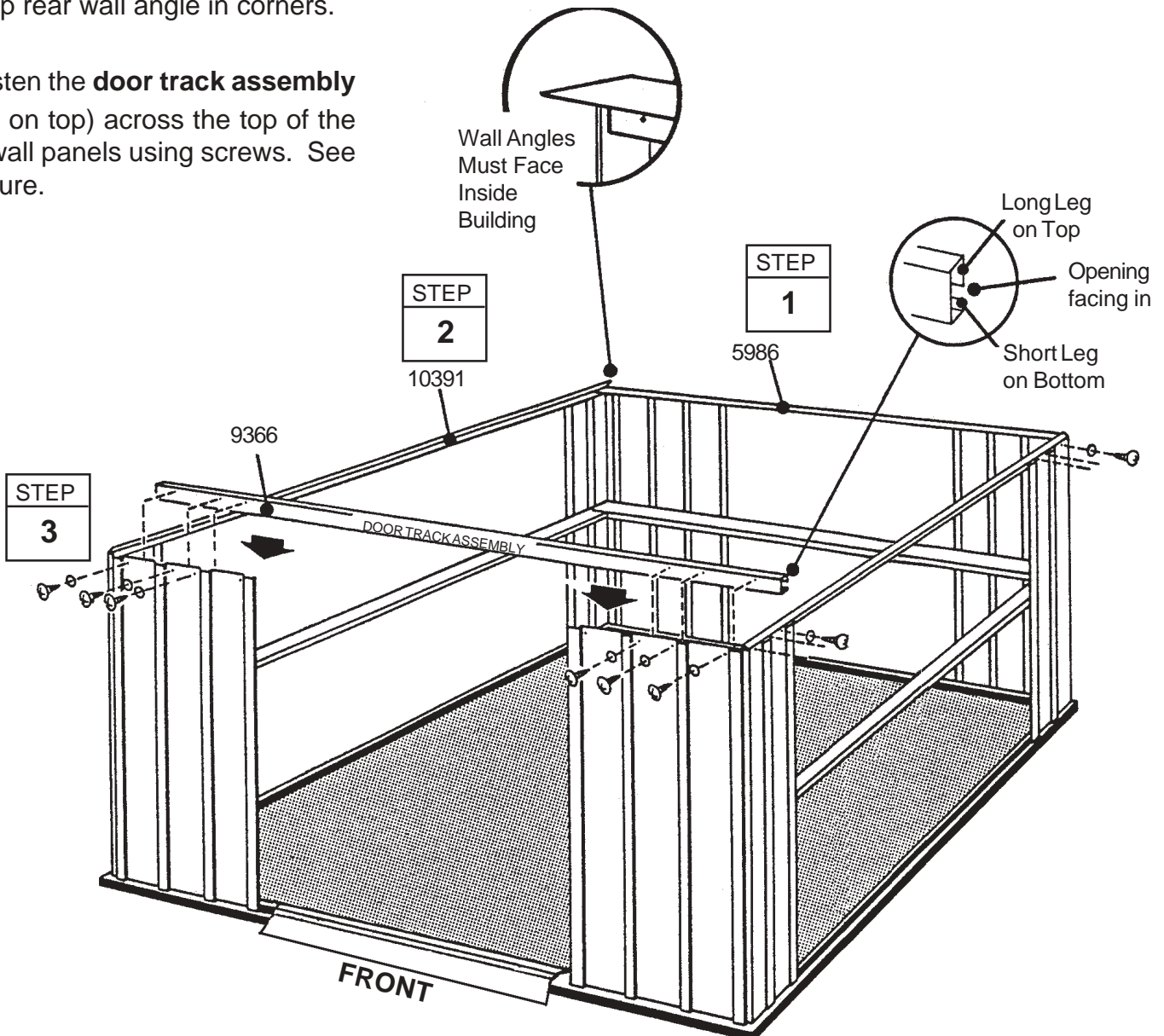

Step 9

SO22

● Parts Needed For ● Wall Panels

● 6515 Wall Panel (10)

Each wall panel has a crimped rib on one side. The crimped rib should go under the rib of the panel that follows it.

- 1** Locate all of the **wall panels** and set each one alongside the building.
- 2** Fasten the wall panels at the top and bottom with screws.
- 3** Fasten the center of each panel to the wall channel with screws.
- 4** Fasten overlapping ribs as before.

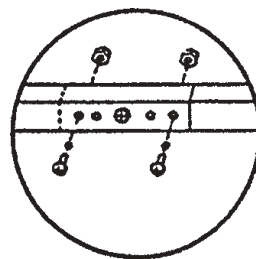
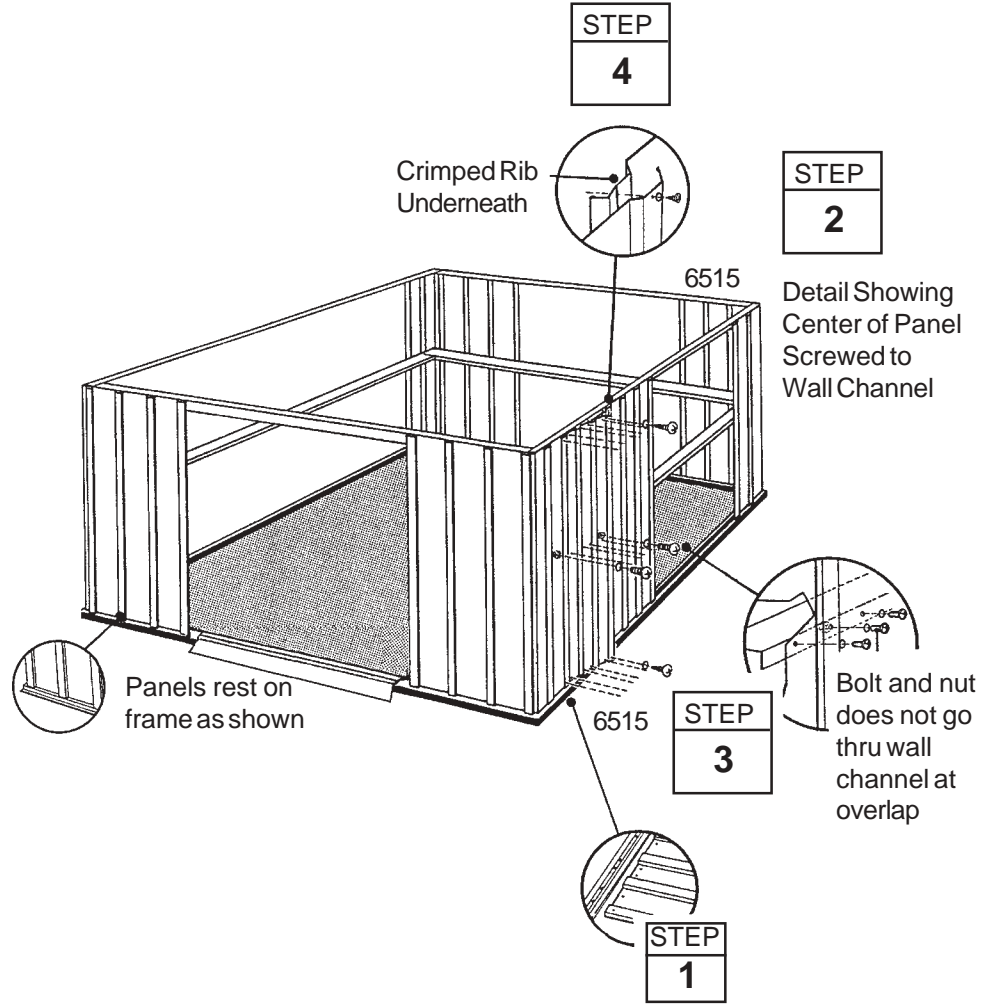

Use bolts and nuts thru wall angle overlap at the top of panel at rear.

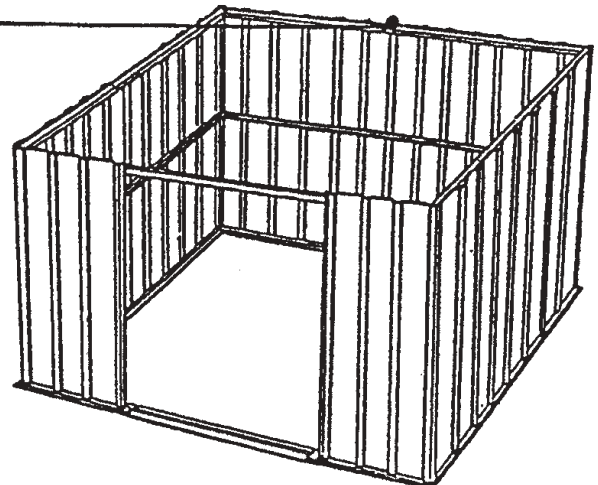

Step 10

S023

● Parts Needed For ● Front Channel/Door Jamb

- 9369 Door Jamb (2)
- 9365 Front Wall Channel (2)

The door jambs reinforce the door opening and provide an attractive trim. Follow these steps for both door jambs.

1 Fasten the **front wall channels** in their positions between the end of the side wall channel and the corner panel using screws. Do not put a screw in the hole at the end behind the door opening at this time.

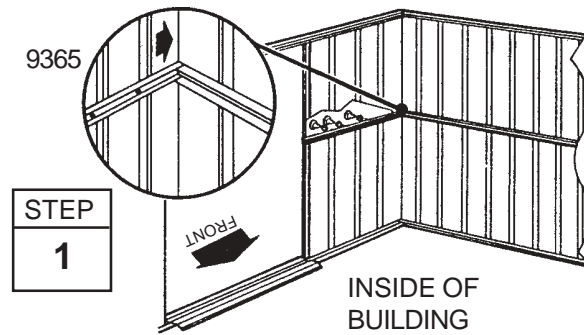

2 Fasten a **door jamb** to the front panel with two bolts, nuts and acorn nuts, as shown.

3 Fasten the center of the door jamb to the front wall panel and the front wall channel with two screws.

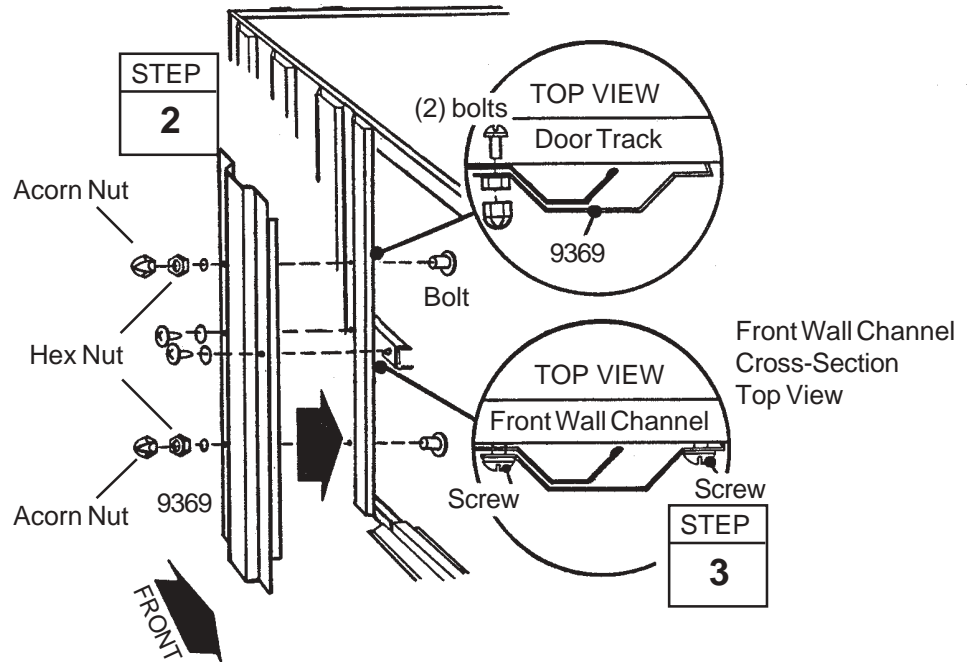

4 Fasten the top of the door jamb to the door track with two screws. Do the same for the bottom into frame.

Repeat steps 2 through 4 for the *opposite* door jamb.

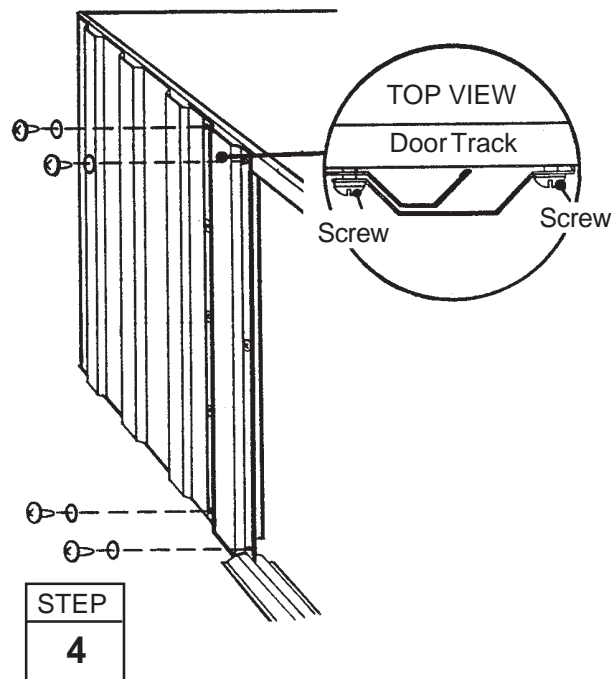

Step 11

SO24

● Parts Needed For ● Gable Assemblies

- 6108 Large Right Gable (2)
- 6109 Large Left Gable (2)
- 6114 Small Right Gable (2)
- 6115 Small Left Gable (2)
- 6085 Roof Beam Bracket (4)

The gables go on top of the front and rear walls to support the roof beams.

NOTE

The gables are packed nested together and might be mistaken as one piece. Carefully separate them before continuing.

1 Apply **edge trim** to the edge of the **large left gable** and the **large right gable**, cut to length.

2 Join the large gables to the small gables on the left and right sides using four bolts, washers and nuts on each side. This part of the gable is called the *outer gable leg*.

3 Attach the four **roof beam brackets** to the outer gable legs using two bolts in the two bottom holes of the four holes that align.

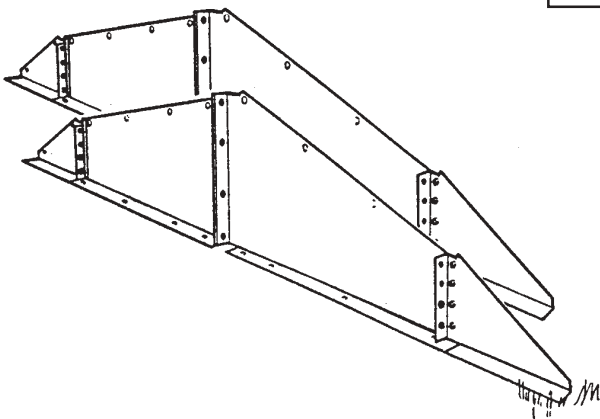
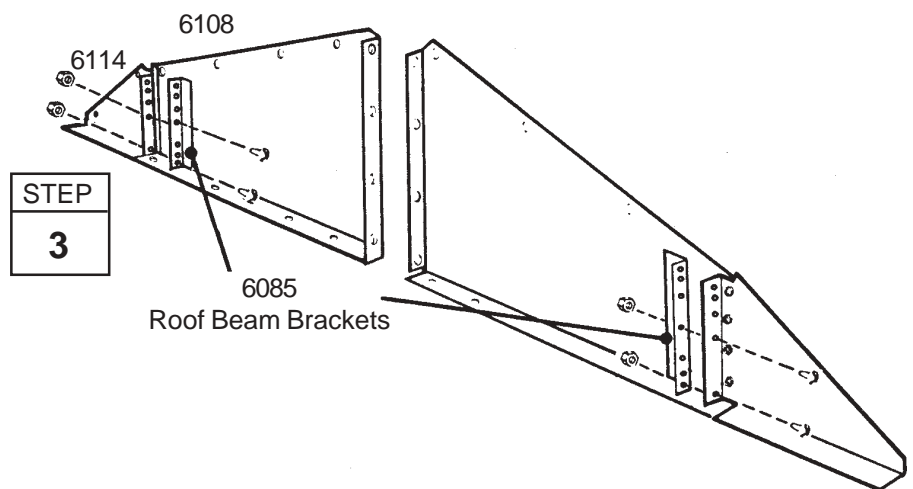
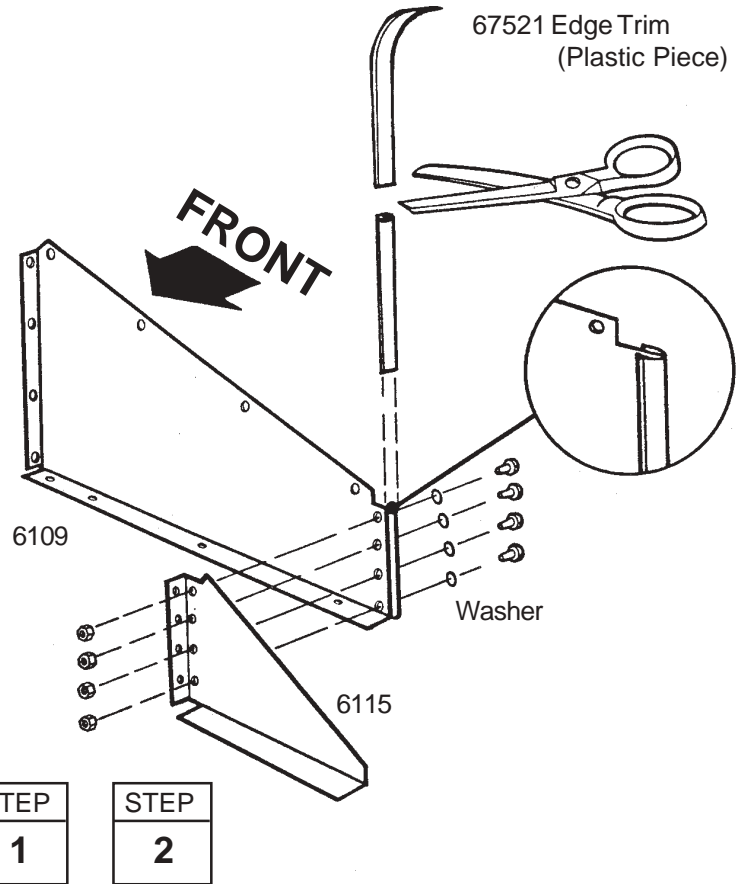

Step 12

SO25

● Parts Needed For ● Gables/Roof Beams

- Left Gable Assemblies (2)
- Right Gable Assemblies (2)
- Single Roof Beam Assemblies (2)
- 6636 Gable Brace (2)

1 Lift and fasten a right and left gable, under angle at corner, to the door track and rear wall angle with screws.

Hint: On the front gable, leave out 2 screws closest to center gable leg. On the rear gable, use a bolt and nut at the overlapping rear wall angle.

2 Fasten the **single roof beam** to the outer gable leg as shown using bolts.

Hint: The holes along the length of the beam must be on the *top* surface.

Repeat Step 1 for the opposite side of building.

3 Join the **left and right gables** together with a **gable brace** using a bolt in the second hole from the bottom *only*. Do this step for both front and rear gables.

Repeat Step 2 for the opposite side of building.

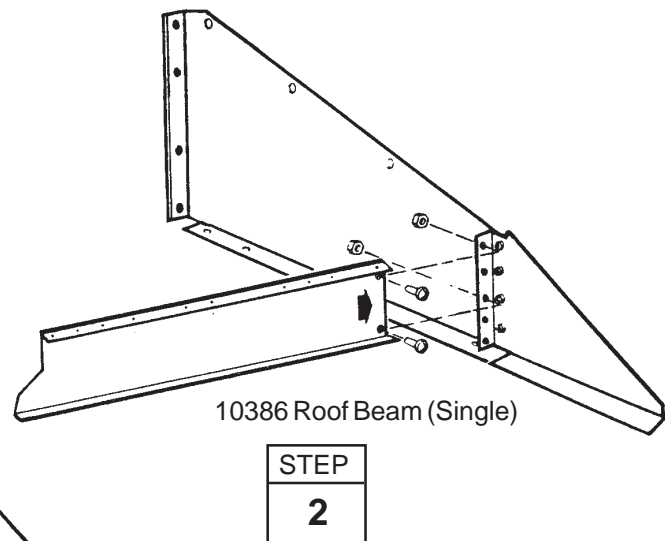
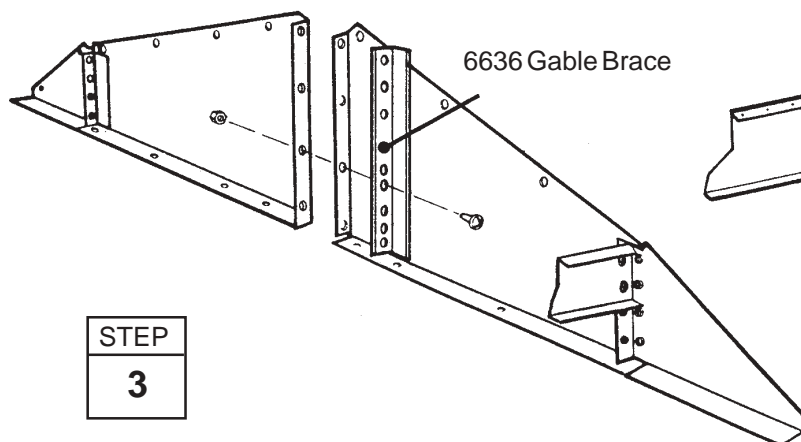
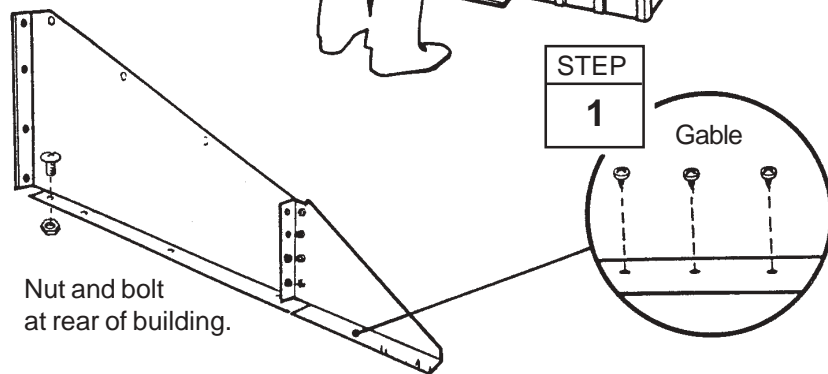
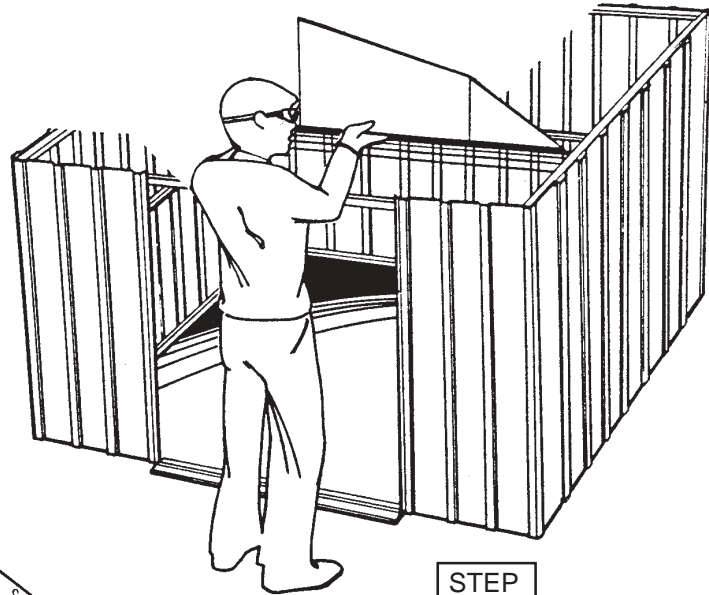

Step 13

S026

● Parts Needed For ● Roof Beam//Braces

- Main Roof Beam Assembly (1)
- 6227 Roof Beam Brace (2)

1 Fasten the **track supports** to the front gable assembly only, as shown.

2 Wrap the **weather stripping** tape around the two joined edges of the large left and right gables. See diagram. Cut the weather stripping to length and repeat on next gable set.

3 Spread the two halves of the double roof beam and fasten to the gable brace of the front gable.

4 Fasten the other end of the double roof beam to the gable brace of the rear gable.

5 Fasten a **roof beam brace** to the double roof beam behind the front gable by placing the tab on the end of the brace *between* the roof beams. Align the tab with the *fourth* hole and fasten the brace with a bolt and nut.

6 Fasten the lower end of the roof beam brace to the **track support** with a bolt and nut.

7 Fasten a **roof beam brace** between the rear gable and the roof beam at the third hole, as shown.

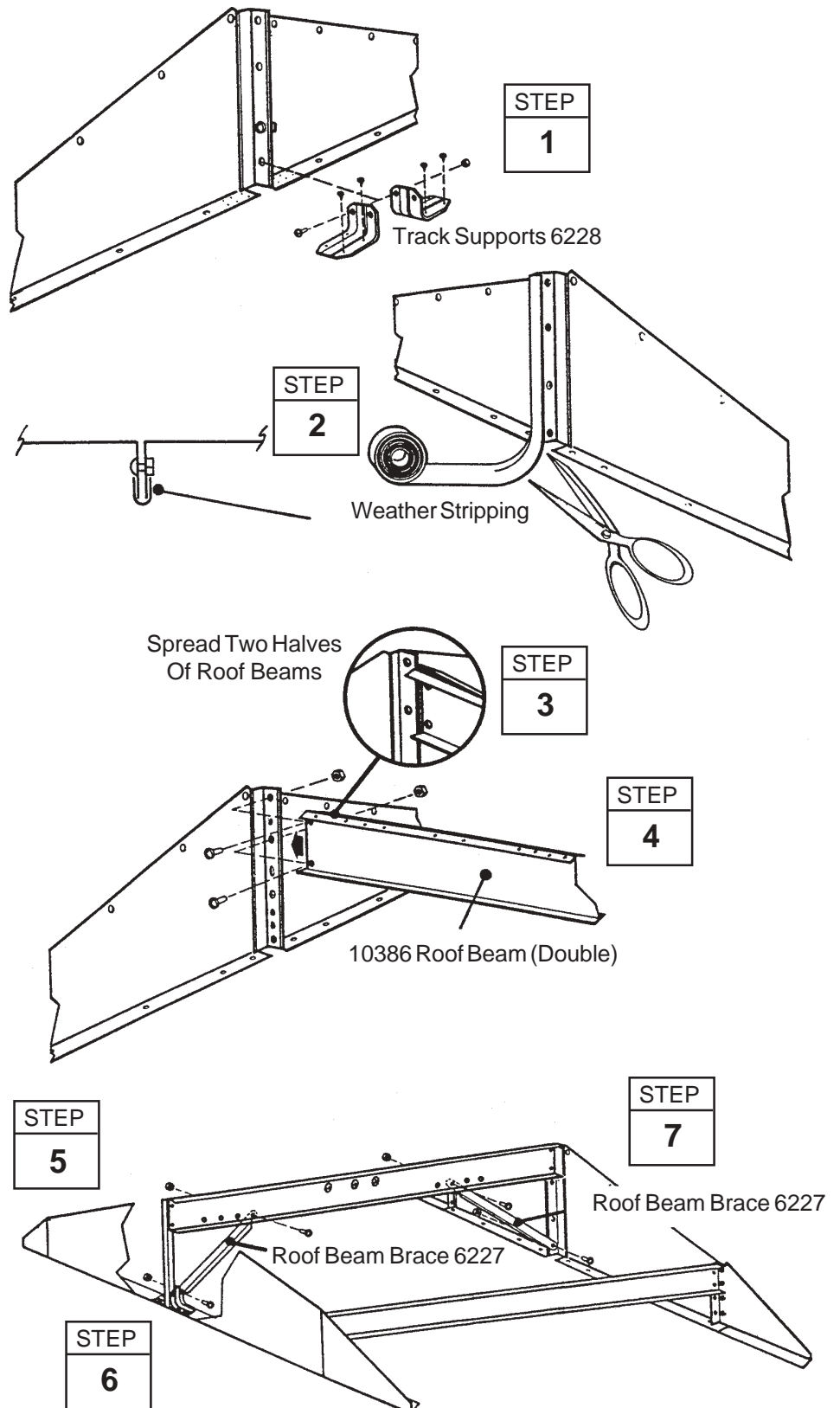

Step 14

S027

● Parts Needed For ● Right Roof Panel

● 6188 Right Roof Panel (1)

Installing the roof panels is best done with a step ladder. Install the first roof panel at the back right corner of the building. Each screw and bolt in the roof requires a washer.

NOTE

Measure the building diagonally again and make adjustments to make sure the building is square and level. This will make the roof panels fit better, and holes will align. Don't anchor the floor frame.

NOTE

If a **Roof Beef-Up Kit** was purchased, assemble prior to attaching the roof panels.

STEP

1

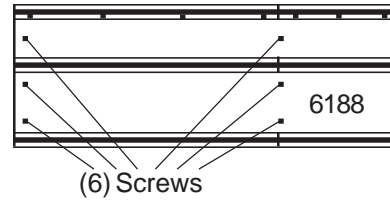

STEP

2

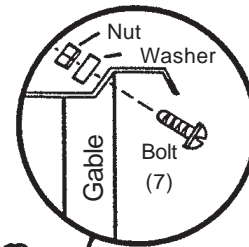

1 Locate the roof panels and find the **right roof panel** part number **6188**.

2 Position the right roof panel at the back right corner and fasten to the gable with seven bolts and nuts and roof beams using six screws. *Do not fasten the lower end of the panel to the side wall angle at this time.*

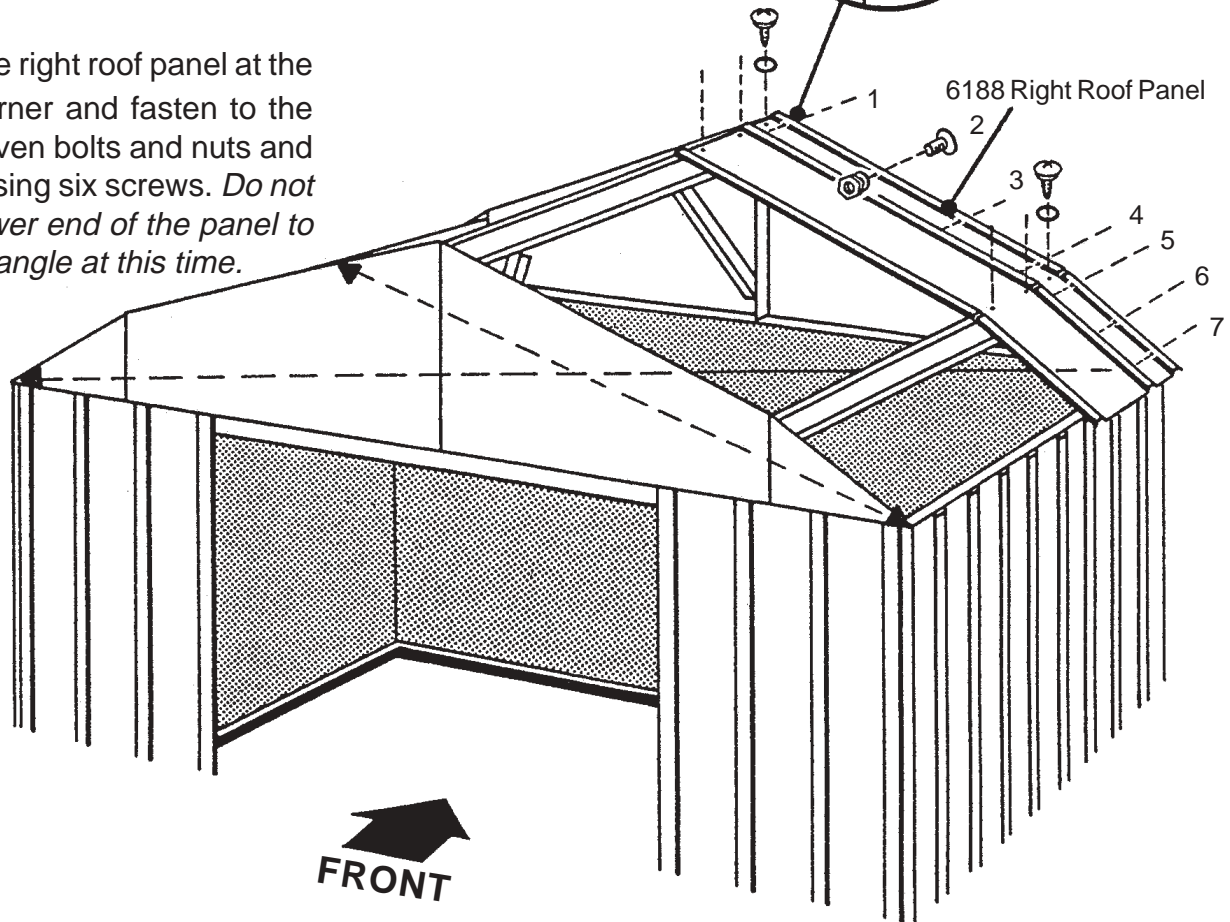

Step 15

SO28

● Parts Needed For ● Ridge Caps & Panels

- 6189 Left Roof Panel (1)
- 6538 Roof Panel (2)
- 6797 Ridge Cap (3)

1 Install a **left roof panel 6189** at the left rear corner of the roof.

2 Cut 34 short (3") strips off the small roll of **weather stripping tape**, and put them aside. Cover the joint at the peak with weather stripping tape, large roll. Unroll the tape and press it down over the opening at the ridge as you install each roof panel. Do not cut the tape at this time.

3 Install two **roof panels 6538** working side to side. Fold the lower section of the roof panels down. Cover the notches with the strips of weather stripping tape. Save the rest. *Do not fasten the lower end of the panels to the side wall angles at this time.* Continue weather stripping the ridge opening.

NOTE

Narrow roof panel crimped rib is overlapped by wide rib of adjacent panel where possible

4 Install three **ridge caps 6797** on the completed roof section using bolts and nuts. Do not fasten the ends of the ridge caps at this time.

5 Fasten the roof panel ribs, **peak caps** and ridge caps together using bolts and nuts.

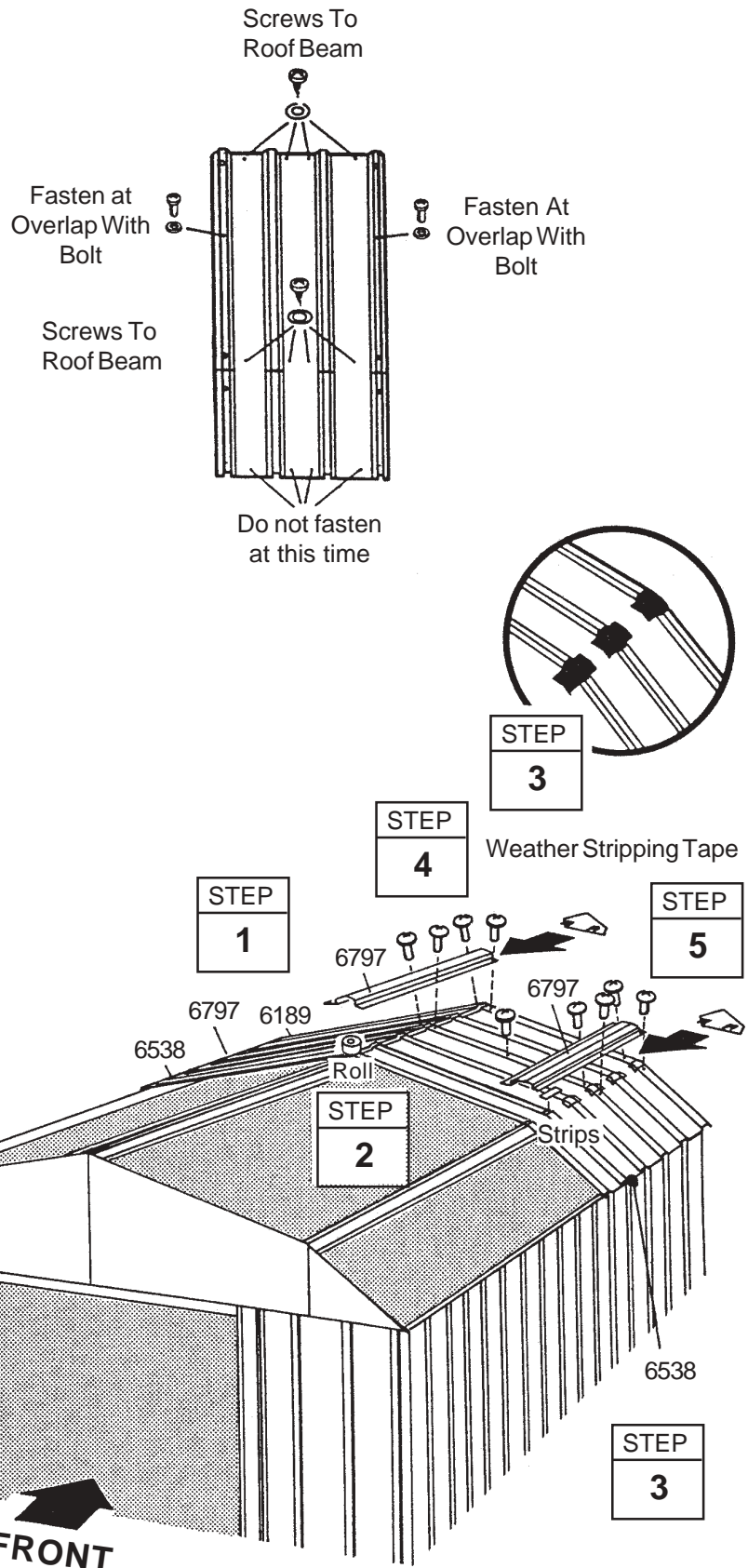

Step 16

SO29

● Parts Needed For ● Ridge Caps & Panels

- 6538 Roof Panel (4)
- 6869 Ridge Cap (3)

1 Install the second **ridge caps 6869** overlapping the first ridge caps while installing four **roof panels 6538**. *Hint: The bolts on the ridge cap need to be left loose to move the ridge cap to the side and overlap the ribs of the next roof panel. Cover the notched areas of the roof panels with strips of weather stripping tape and continue weather stripping the ridge.*

NOTE

If roof beam holes do not line up with the roof panel holes, shift the building from left to right. If this does not help, your building may not be level. Shim the corners until holes line up.

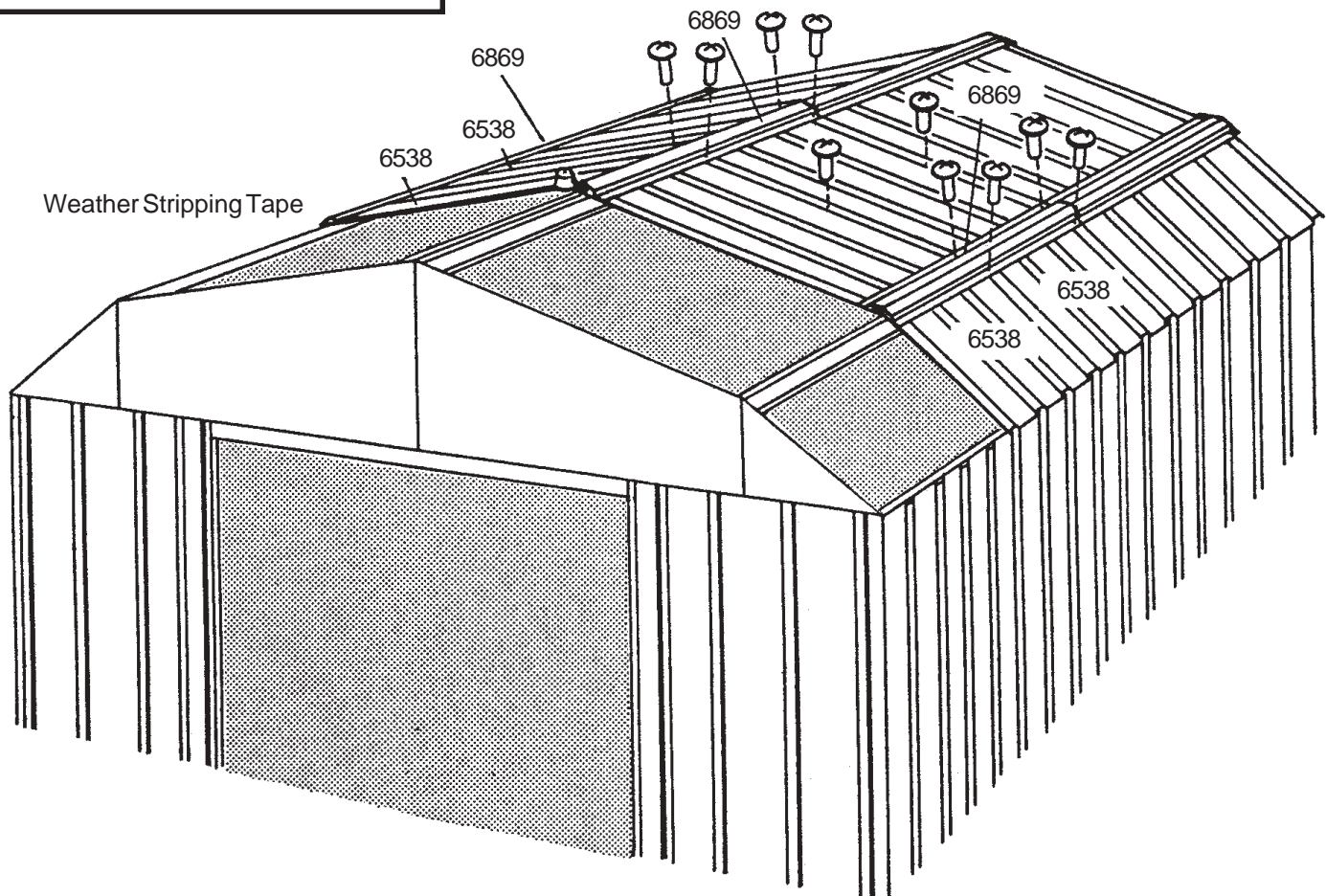

Step 17

S030

● Parts Needed For ● Ridge Caps & Panels

- 6538 Roof Panel (2)
- 6797 Ridge Cap (3)
- 6188 Right Roof Panel (1)
- 6189 Left Roof Panel (1)

1 Install the third **ridge caps 6797** overlapping the second ridge caps while installing the remaining **roof panels 6538**. *Hint: The bolts on the ridge cap need to be left loose to move the ridge cap to the side and overlap the ribs of the next roof panel.* Cover the notched areas of the roof panels with strips of weather stripping tape and continue weather stripping the ridge.

2 Install the **left 6189** and **right roof panel 6188** as you unroll the weather stripping tape, and press it down. Fasten the lower end of the panels to the side wall angles using screws and washers.

3 Fasten the roof panel ribs, **peak caps** and ridge caps together using bolts and nuts.

Reducing Large Gable Bulge

Loosen eight bolts and nuts shown. Apply pressure with one hand at the peak of the gable and tighten bolt #1. Keeping pressure on the gable work down the slope tightening each bolt. Excess material will overlap smaller gable at seam. Once material bulge is worked out tighten four vertical bolts that connect the large and small gables.

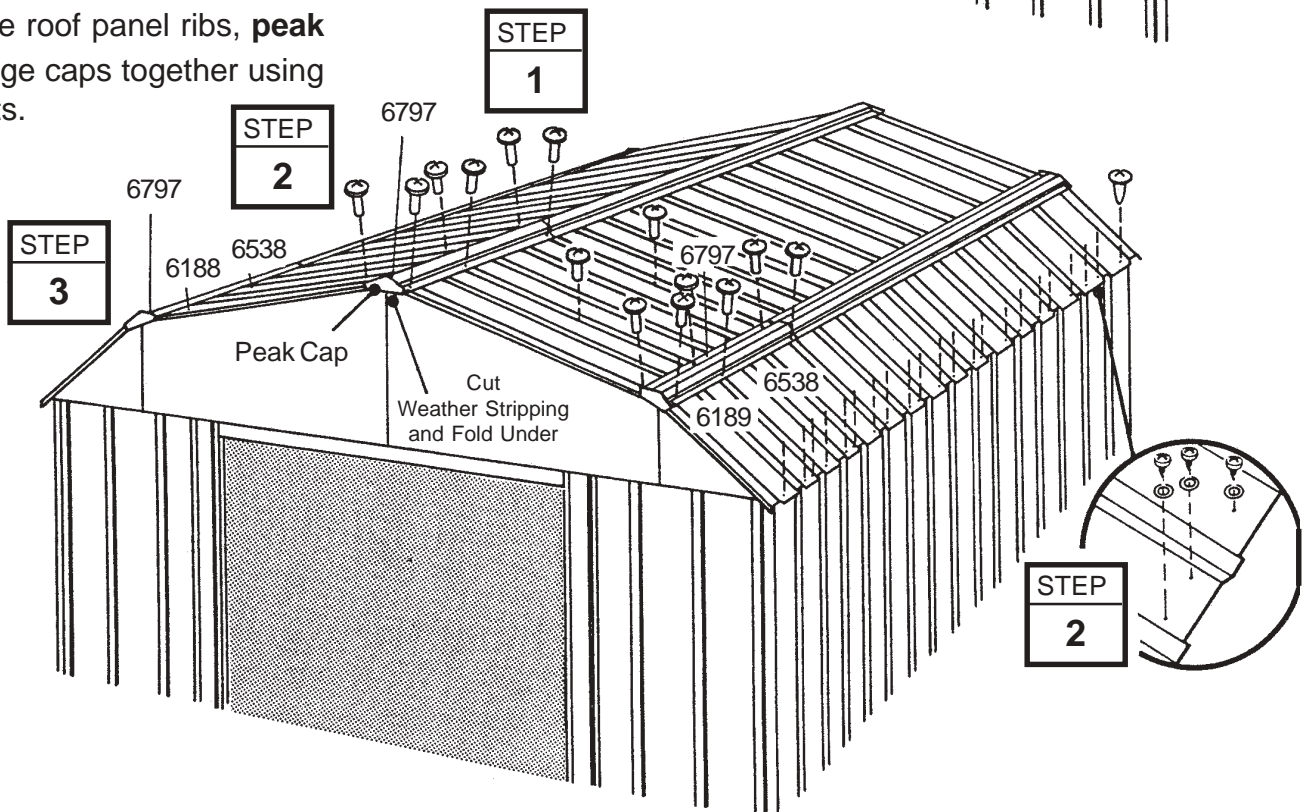
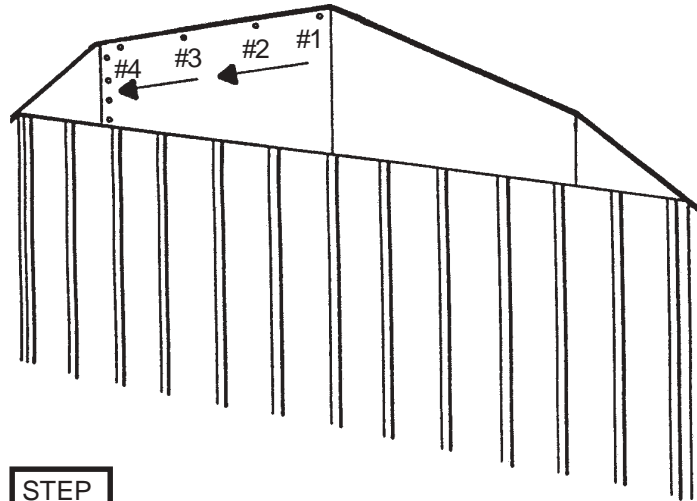

Step 18

S031

● Parts Needed For ● Roof Trim

- 6893 Left Side Roof Trim (2)
- 6892 Right Side Roof Trim (2)
- 6015 Side Roof Trim (2)

1 Attach the **right, left and side roof trim** to the lower end of the roof panels on each side of the building using screws at each panel overlap.

NOTE

A single screw fastens both trim pieces at the overlap.

2 Using your thumb and index finger, overbend the bottom flange of the roof panel rib at the corner inward enough so the right and left roof trim caps fit onto right and left corners.

3 Fasten the roof trim caps to the side trim using a screw.

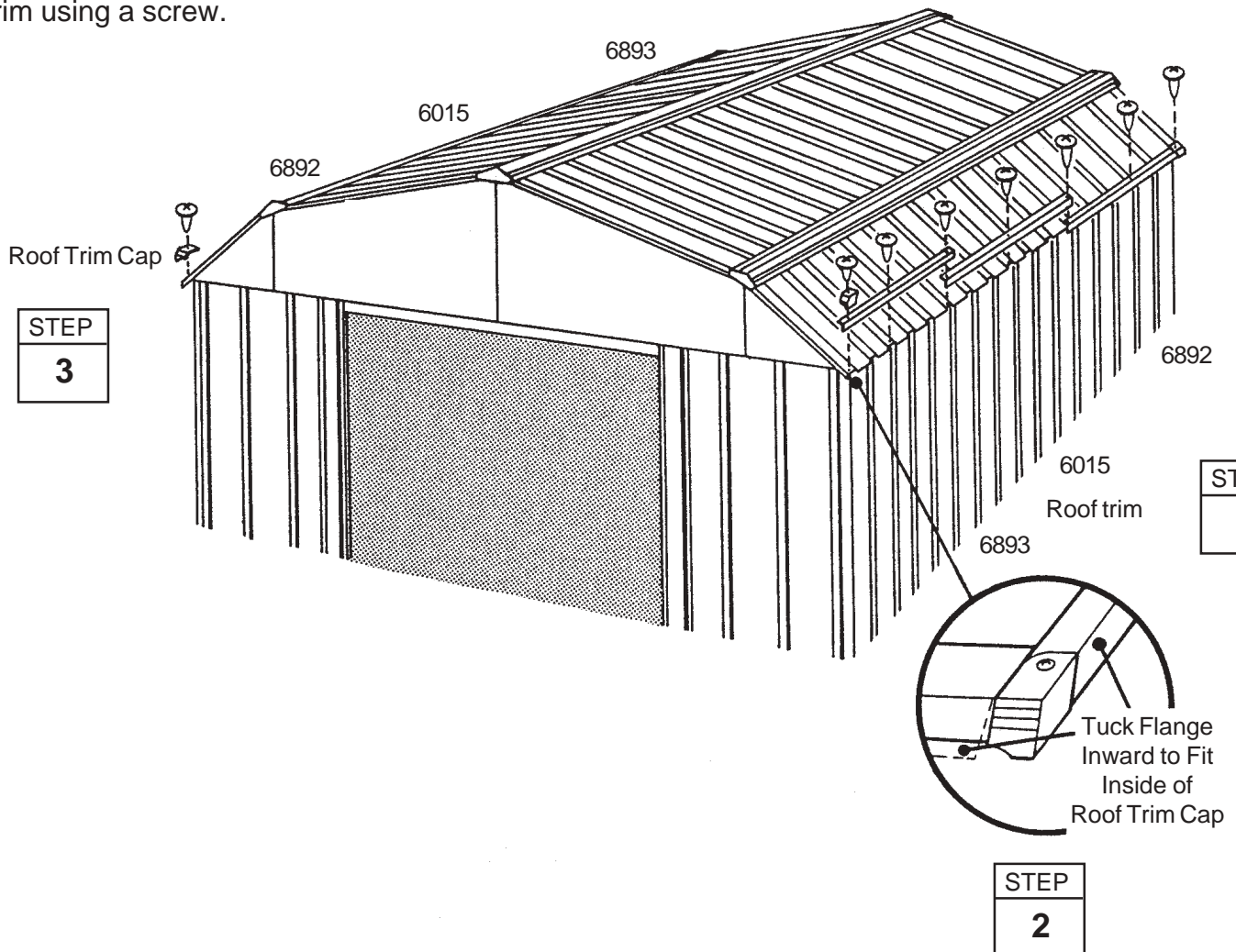

Step 19

SO32

● Parts Needed For ● Door Assembly

- 3719 Door Handle Brace (2)
- 8538 Right Door (1)
- 8539 Left Door (1)
- 6264 Horizontal Door Brace (4)
- 6278 Vertical Door Brace (2)

The steps on this page tell how to assemble the right door. You will perform exactly the same procedures for the left door. Each bolt and screw in the door requires a washer. Proceed as follows:

1 Attach the **door handle brace** and **handle** to the **door** with 1 bolt as shown. *Don't tighten the bolt yet.*

2 Swing the door handle brace up to the hole on the center of the door and insert a screw.

3 Hold the **vertical door brace** against the center of the inside surface of the door and turn the screw to hold the vertical door brace and door handle brace in place. Fasten to door above and below center connection using 2 screws.

4 Insert a second bolt in the door handle and tighten both bolts.

5 Put a **horizontal door brace** onto the top edge and bottom edge and fasten *with 1 bolt in the center.*

6 Attach the **lower door guides** as shown.

7 Repeat steps 1 through 6 for the **left door**.

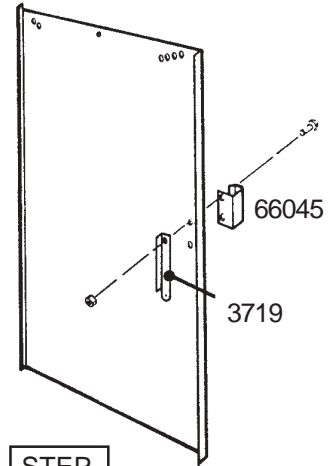
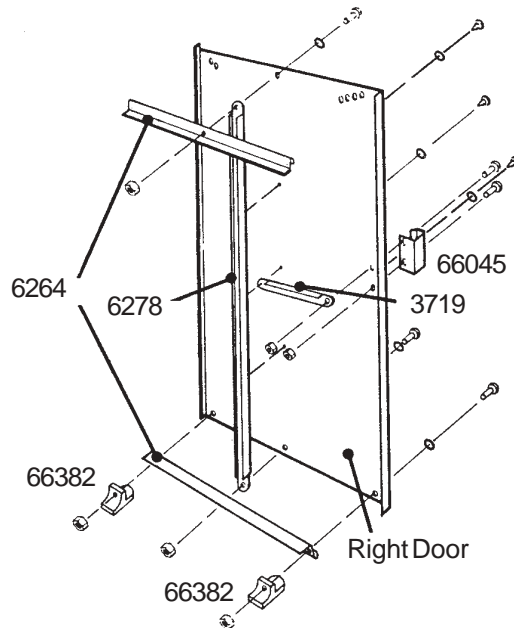

STEP
1

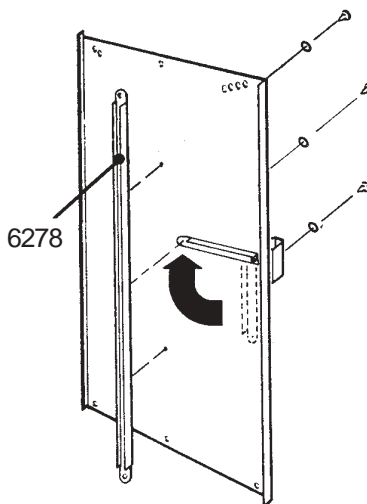

STEP
2

STEP
3

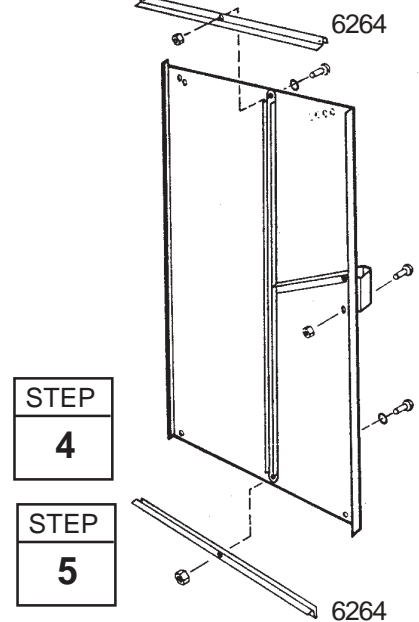

STEP
4

STEP
5

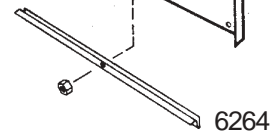

END VIEW
SHOWING:

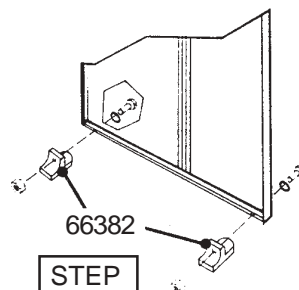

STEP
6

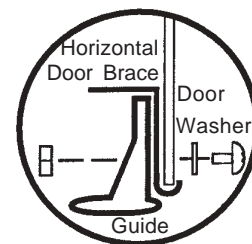

Step 20

SQ33

● Parts Needed For ● Door Installation & Adjustment

- Right Door Assembly (1)
- Left Door Assembly (1)

1 From inside the building, put the bottom of the right door assembly (on your left when you are inside the building) behind door jamb into the front frame track.

2 Position the top of the door so that the holes in the door line up with the holes in the door slides.

3 Fasten the door to the door slides using a #10Bx1/2" screw.

NOTE

The four holes in the top of each door allow you to adjust the doors. Place the door slide in the middle 2 holes.

4 Repeat steps 1 through 3 for the left door.

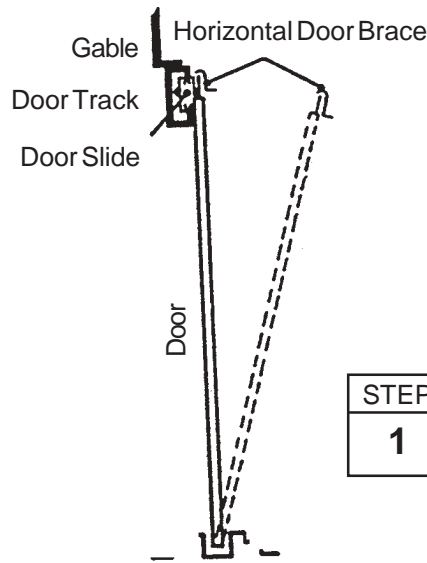

Front Floor Frame Assembly

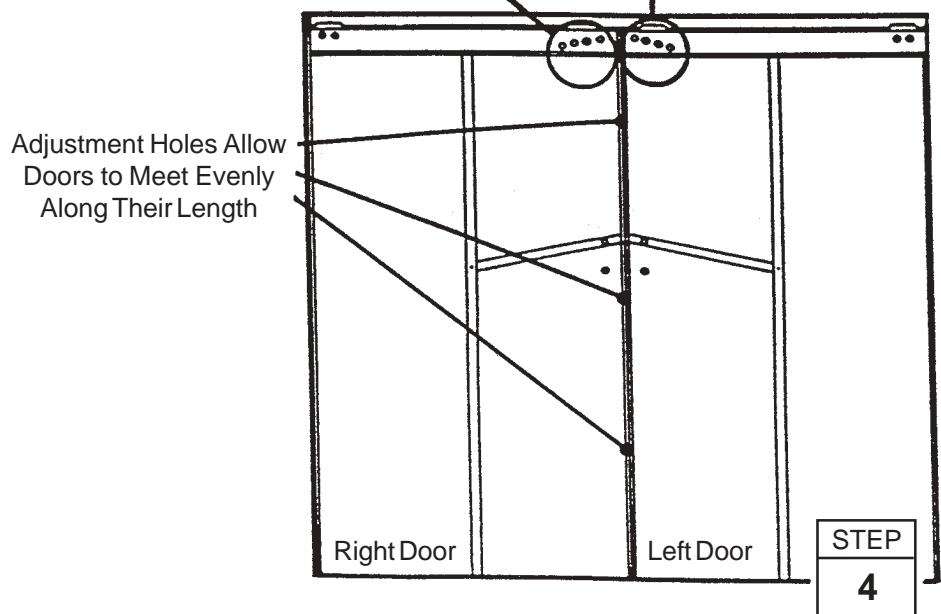
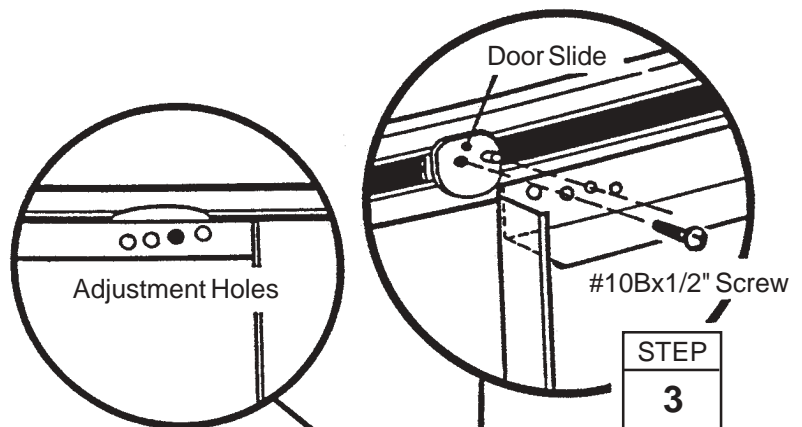

SOME FACTS ABOUT RUST

SO34

SOME FACTS ABOUT RUST

Rusting is a natural oxidizing process that occurs when bare metal is exposed to moisture. Problem areas include screw holes, unfinished edges, or where scrapes and nicks occur in the protective coating through normal assembly, handling and use. Identifying these natural rusting problem areas and taking some simple rust protection precautions can help to stop rust from developing, or stop it quickly as soon as it appears.

1. Avoid nicking or scraping the coating surface, inside and out.
2. Use all the washers supplied. In addition to protecting against weather infiltration, the washers protect the metal from being scraped by the screws.
3. Keep roof, base perimeter and door tracks free of debris and leaves which may accumulate and retain moisture. These can do double damage since they give off acid as they decay.
4. Touch up scrapes or nicks and any area of visible rust as soon as possible. Make sure the surface is free of moisture, oils, dirt or grime and then apply an even film of high quality touch-up paint.

CO1014-B	DG1014-A	DK1014-A	LX1014-B	RV1014-A
TSC1014	VS1014-B	VY1014	WV1014-B	YT1014-B
	697.68604	697.68630	697.68756-C	

S036