

Owner's Manual & Assembly Instructions

BI01

Model No. **BW54-A** **BWG54** **BWW54**
 YL54 **YL54M**

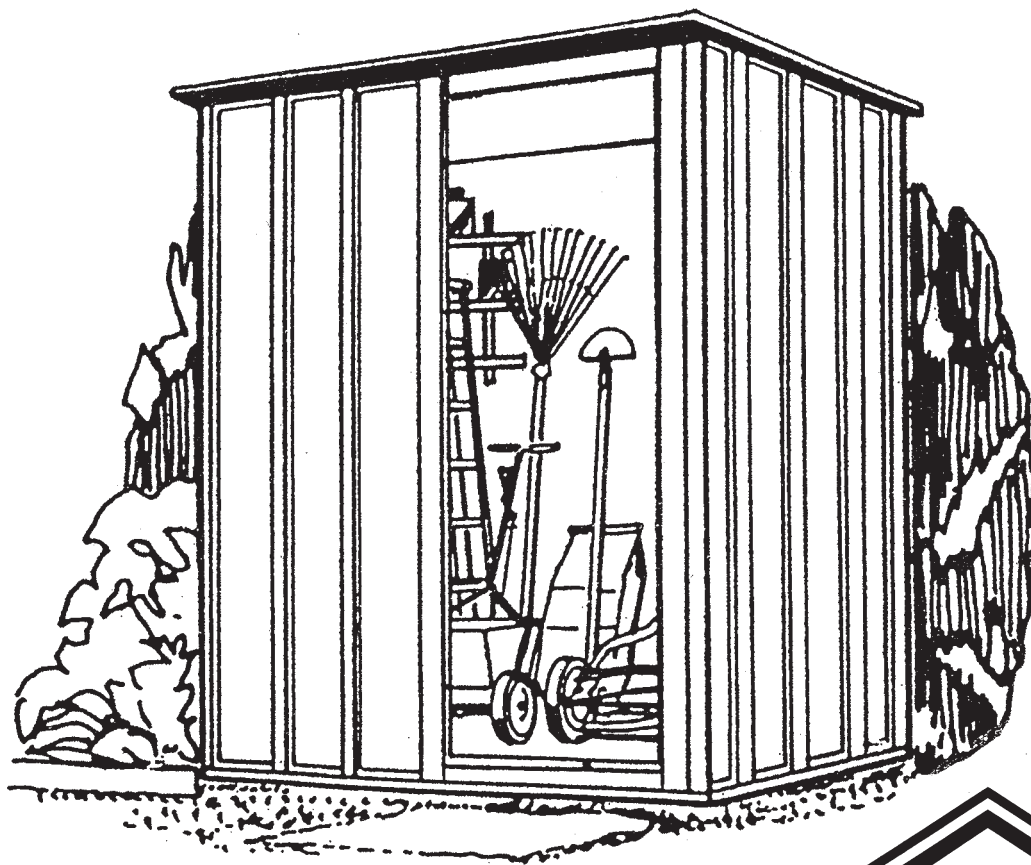

709181207

BUILDING DIMENSIONS * Size rounded off to the nearest foot



CAUTION: SOME PARTS HAVE SHARP EDGES. CARE MUST BE TAKEN WHEN HANDLING THE VARIOUS PIECES TO AVOID A MISHAP. FOR SAFETY SAKE, PLEASE READ SAFETY INFORMATION PROVIDED IN THIS MANUAL BEFORE BEGINNING CONSTRUCTION. WEAR GLOVES WHEN HANDLING METAL PARTS.

*Approx. Size	Foundation Size	Storage Area Sq. Ft. Cu. Ft.		Exterior Dimensions (Roof Edge to Roof Edge)			Interior Dimensions (Wall to Wall)			Door Opening	
				Width	Depth	Height	Width	Depth	Height	Width	Height
5' x 4'	57" x 45 7/8"	16	93	59 1/2"	48"	70 3/4"	54 1/4"	43 1/8"	69 1/2"	22 1/4"	65"
1,4m x 1,1m	145cm x 117cm	1,5m ²	2,6m ³	151cm	122cm	180cm	138cm	110cm	177cm	57cm	165cm

BEFORE YOU BEGIN....

A2

Owner's Manual

Before beginning construction, check local building codes regarding footings, location and other requirements. Study and understand this owner's manual.

Important information and helpful tips will make your construction easier and more enjoyable.

Assembly Instructions: Instructions are supplied in this manual and contain all appropriate information for your building model. Review all instructions before you begin, and during assembly, follow the step sequence carefully for correct results.

Foundation and Anchoring: Your storage building must be anchored to prevent wind damage. A foundation is also necessary as a base in order to construct a square and level building. Anchoring and foundation materials are not included with your building. We recommend the combined use of an **Arrow Floor Frame Kit** and an **Arrow Anchoring Kit** as an effective method of securing your building to the ground (Available by mail order or at your local dealer) or you may construct a foundation and anchoring system of your choice. Your assembly instructions provide information on a few methods commonly used to secure and level a storage building.

Parts and Parts List: Check to be sure that you have all the necessary parts for your building.

- All part numbers can be found on the parts. All of these numbers (before the -) must agree with the numbers on the parts list. The parts list is located on page 12.

- If you find that a part is missing, include the model number of your building and contact:

Arrow Group Industries, Inc. Customer Service Department
Route 50 East Breese, Illinois 62230
1-800-851-1085

- Separate contents of the carton by the part number while reviewing parts list. The first few steps show how to join related parts to make larger sub assemblies which will be used later.

- Familiarize yourself with the hardware and fasteners for easier use during construction. These are packaged within the carton. Note that extra fasteners have been supplied for your convenience.

PLAN AHEAD....

A3

Watch the Weather: Be sure the day you select to install your building is dry and calm. Do not attempt to assemble your building on a windy day. Be careful on wet or muddy ground.

Teamwork: Whenever possible, two or more people should work together to assemble your building. One person can position parts or panels while the other is able to handle the fasteners and the tools.

Tools and Materials: These are some basic tools and materials you will need for the construction of your building. Decide which method of anchoring and the type of foundation you wish to use in order to form a complete list of the materials you will need.

<p>Required</p> <ul style="list-style-type: none"> • Eye Goggles • No. 2 Phillips Screwdriver (With Hardened Magnetic Tip) <p>Note: A power screwdriver or variable speed drill with Phillips-tip attachment can speed assembly by as much as 40%.</p>	<p>Required</p> <ul style="list-style-type: none"> • Work Gloves • Step Ladder • Utility Knife / Scissors • Pliers • Carpenter's Level • Tape Measure 	<p>Optional Time-Savers</p> <ul style="list-style-type: none"> • Wrench / Nut Driver • Electric / Cordless Drill • Square • String (for squaring frame) 	<p>Foundation Preparation</p> <ul style="list-style-type: none"> • Hammer and Nails • Spade or Shovel • Hand Saw / Power Saw • Lumber and/or Concrete
--	---	---	---

Selecting and Preparing Your Site: Before assembly, you will want to decide on a location for your building. The best location is a level area with good drainage.

- Allow enough working space for ease of moving parts into position during assembly. Be sure there will be enough space at entrance for doors to open fully and enough space around the building to be able to fasten the panel screws from the outside.

- Before you begin the first steps in assembling your parts, a foundation should be constructed and an anchoring system should be ready to use.

SAFETY FIRST...

A4

Safety precautions are important to follow throughout the construction of your building.

•Care must be taken when handling various pieces of your building since some contain sharp edges. Please wear work gloves, eye protection and long sleeves when assembling or performing any maintenance on your building.

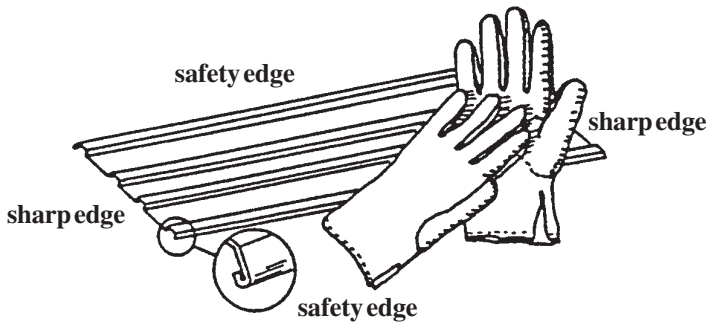

•Keep children and pets away from worksite to avoid distractions and any accidents which may occur.



•Never concentrate your total weight on the roof of the building. When using a step ladder make sure that it is fully open and on even ground before climbing on it.

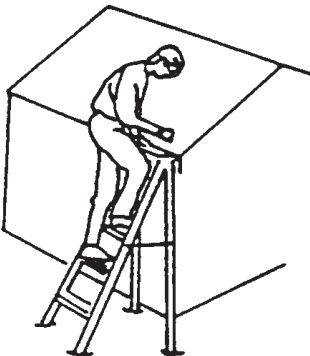

•Practice caution with the tools being used in the assembly of this building. Be familiar with the operation of all power tools.

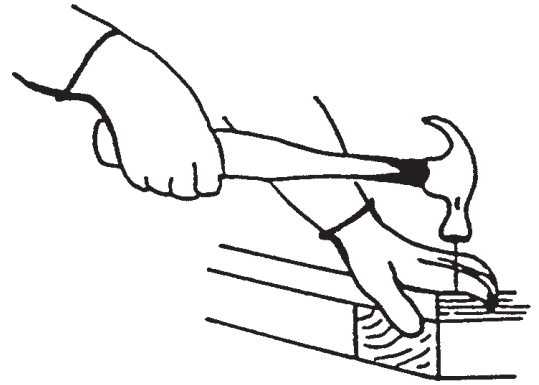

•Do not attempt to assemble the building if parts are missing because any building left partially assembled may be seriously damaged by light winds. Call 1-800-851-1085

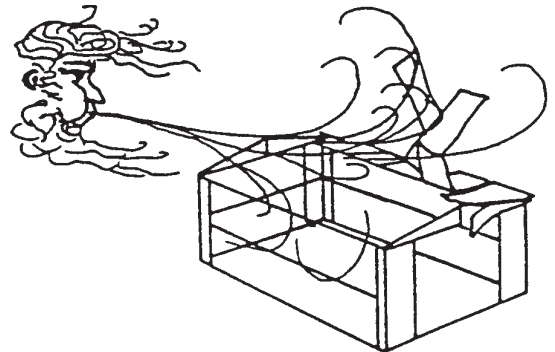

•Do not attempt to assemble the building on a windy day, because the large panels acting as a "sail", can be whipped about by the wind making construction difficult and unsafe.

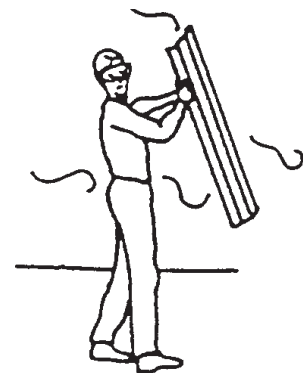

CARE & MAINTENANCE....

A5 Web

Finish: For long lasting finish, periodically clean and wax the exterior surface. Touch-up scratches as soon as you notice them on your unit. Immediately clean the area with a wire brush; wash it and apply touch-up paint per manufacturer's recommendation.

Roof: Keep roof clear of leaves and snow with long handled, soft-bristled broom. Heavy amounts of snow on roof can damage building making it unsafe to enter. In snow country, Roof Strengthening Kits are available for most Arrow Buildings for added protection against heavy snow accumulation.

Doors: Always keep the door tracks clear of dirt and other debris that prevent them from sliding easily. Lubricate door track annually with furniture polish or silicone spray. Keep doors closed and locked to prevent wind damage.

Fasteners: Use all washers supplied to protect against weather infiltration and to protect the metal from being scratched by screws. Regularly check your building for loose screws, bolts, nuts, etc. and retighten them as necessary.

Moisture: A plastic sheet (vapor barrier) placed under the entire floor area with good ventilation will reduce condensation.

Other Tips....

- Wash off inked part numbers on coated panels with soap and water.
- Silicone caulking may be used for watertight seals throughout the building.

Do not store swimming pool chemicals in your building. Combustibles and corrosives must be stored in air tight approved containers.

Keep this Owner's Manual and Assembly Instructions for future reference.

ACCESSORIES...

A6 WEB

ROOF STRENGTHENING (heavy snow load) KITS

Extra roof beams and gable braces designed for added protection against heavy snow accumulation. Increases the strength of your roof by 50%.

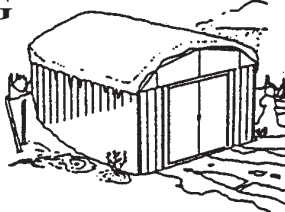

ANCHOR KITS

Model No. AK4

Anchor Kit contains heavy-duty steel augers, 60' (18m) of steel cable and 4 cable clamps. No digging or concrete pouring, just insert cable under roof, over roof beams, into augers and twist augers into the ground. For buildings larger than 10'x9', use 2 kits.

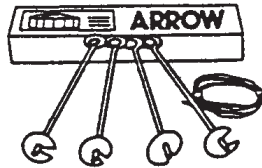

Model No. AK100

New concrete anchor system permits anchoring any size Arrow building directly to a concrete slab. Each kit contains heavy-duty, hot-dipped galvanized steel corner gussets and perimeter clips which fit over the floor frame and lag bolt into a concrete slab. Full assembly instructions and a 1/4" masonry drill bit are included.

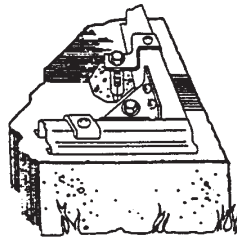

Model No. AK600

Earth Anchor Kit anchors any size Arrow building to the ground. Each kit contains heavy duty, hot-dipped galvanized steel corner gussets and 4 earth anchors.

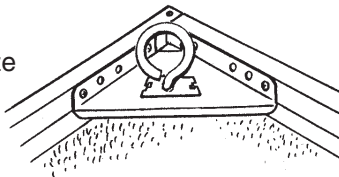

TOOL HANGING RACK

Model No. TH100

The perfect tool organizer. Twin 25 1/2" (65cm) steel channels plus five heavy-duty snap-in hangers and a small tool holder for screwdrivers, pliers, etc. Holders slide along channel for fully adjustable spacing. Great for garage, basement, or the back of any door. Fits all Arrow storage buildings.

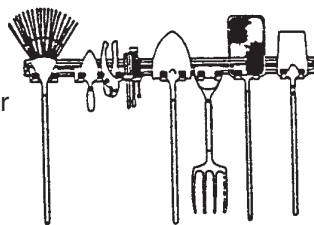

FLOOR FRAME KITS



MODELS FB47410, FB5465, FB106-A
FB109-A and FB1014-A

A simple new floor frame system made of heavy-duty, hot-dipped galvanized steel. Use as foundation for plywood, sand or stone.

ATTIC KIT / WORKBENCH KIT

Heavy-duty galvanized steel bars that fit all 10' wide Arrow buildings. They install quickly and easily to help organize space and create more useable space as an attic or workbench. Will hold up to 250 lbs. (113kg) evenly distributed.



Model No.	Fits	Shipping Weight
AT101	10' Long, 250 lb. (113kg) load+ Fits all Arrow 10' wide buildings.	16 lbs. (7kg)

Must be drilled for use as workbench in Estator.
+ Even weight distribution.

SHELF UNITS

Heavy-duty, galvanized steel shelf units help organize storage space. They easily mount on the wall or sit on the floor. Fits all Arrow buildings.*

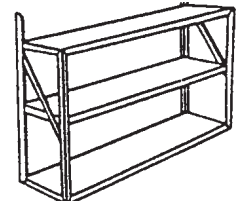
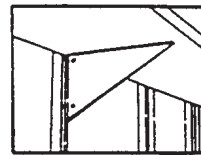
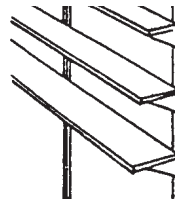

Model No. SS404

- Makes 8" to 12" (20-30cm) wide shelves in any length.
- Brackets, braces, hardware included. Lumber is not included.

Model No. SS900-A

- Grey color
- 3 shelves
- Holds up to 85 lbs. (38kg) (even weight distribution)

* Some drilling required to fit buildings without mid-wall bracing.

THIS
PAGE
WAS
LEFT
BLANK
INTENTIONALLY



THIS

PAGE

WAS

LEFT

BLANK

INTENTIONALLY

Foundation

B109

The Foundation For Your Building



OPTION 1: ARROW FLOOR FRAME KIT: (Order No. FB5465)

Arrow has the best base for your building in this simple kit. It keeps stored items above the ground. This kit should be used with one of the following:

A. To support a plywood deck **B.** To be filled with sand. We recommend the combined use of **1.** an **ARROW FLOOR FRAME KIT** and **2.** an **ARROW ANCHORING KIT** as an effective method of securing the building to the ground. **Allow 1 - 2 hours for construction.**

OPTION 2: Wood Platform

If you decide to build your own foundation, be sure to select the appropriate materials.

These are the recommended materials for your foundation:

- 2 x 4's (5cm x 10cm) Pressure Treated Lumber
- 5/8" (1,5cm) 4 x 8 (122cm x 244cm) Plywood-exterior grade
- 10 & 4 penny Galvanized Nails
- Concrete Blocks (optional)

The platform should be level and flat (free of bumps, ridges etc.) to provide good support for the building. The necessary materials may be obtained from your local lumber yard.

To construct the foundation follow instructions and diagram.

Construct frame (using 10 penny galvanized nails)
Measure 16"/24" (40,6cm/61cm) sections to construct inside frame (see diagram)
Secure plywood to frame (using 4 penny galvanized nails)

Allow 6 - 7 hours for construction.

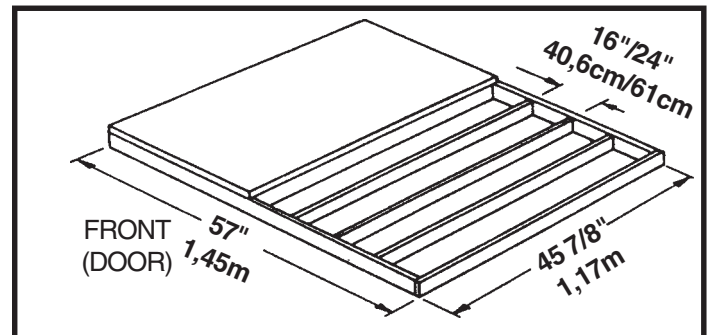

Note: Platform/Slab will extend 9/16" (1,4cm) beyond floor frame on all four sides. Seal this 9/16" of wood with a roofing cement (not included), or bevel this 9/16" of concrete when pouring, for good water drainage.

OPTION 3: Concrete Slab

The slab should be at least 3" to 4" (8-10cm) thick. It must be level and flat to provide good support for the frame.

The following are the recommended materials for your foundation.

- 1 x 4's (2,5cm x 10cm) (will be removed once the concrete cures)
- Concrete
- Sheet of 6 mil plastic
- We recommend for a proper strength concrete to use a mix of:
1 part cement ● 3 parts pea sized gravel ● 2 1/2 parts clean sand

Prepare the Site/Construct a Foundation

1. Dig a square, 6" (15cm) deep into the ground (remove grass).
2. Fill up to 4" (10cm) in the square with gravel and tamp firm.
3. Cover gravel with a sheet of 6 mil plastic.
4. Construct a wood frame using four planks of 1x4 (2,5cm x 10cm) lumber.
5. Pour in concrete to fill in the hole and the frame giving a total of 4" (8-10cm) thick concrete. Be sure surface is level.

Allow 3 - 5 hours for construction and a week for concrete curing time.

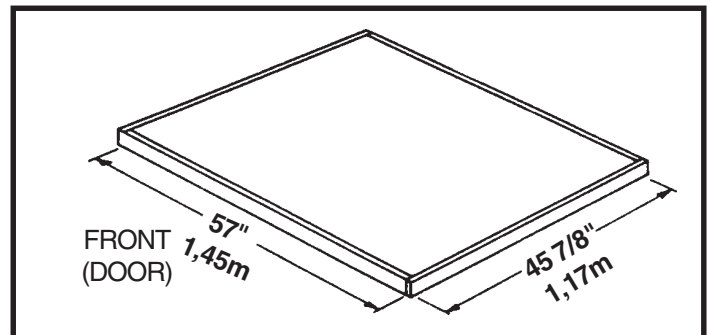

Note: Finished Slab dimensions, with lumber removed.

Anchoring

A10

Anchoring Down The Building

It is important that the entire floor frame be anchored after the building is erected.

Below are recommended ways of anchoring.

Arrow Anchoring Kit: (Model No. AK4 or 60298)

Recommended for use with **any** suggested **base**.

Contains: 4 Anchors with Cable, Clamps and installation instruction.

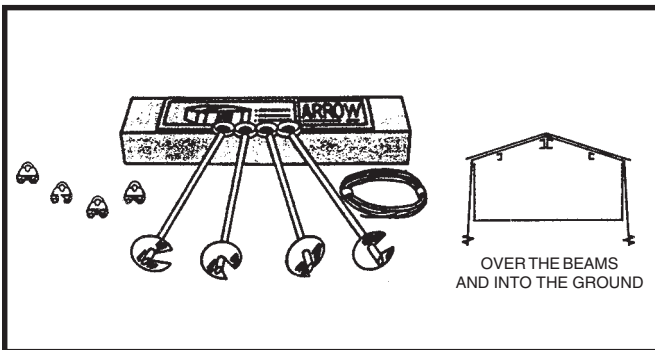

Anchoring into Wood/Post:

Use 1/4" Wood Screws. There are 1/4" (0,63cm) dia. holes provided in the frames for proper anchoring.

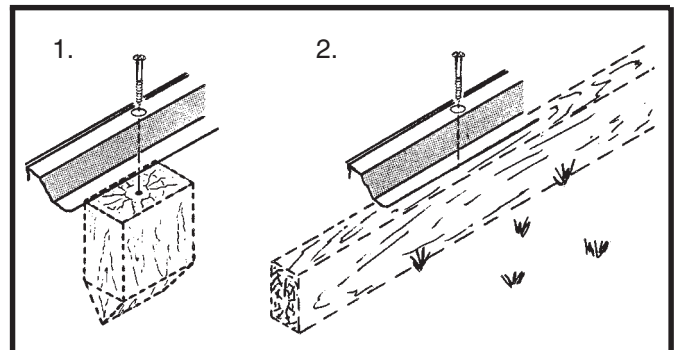

Arrow Anchoring Kit: (Model No. AK100 or 68383)

Recommended for use with the **concrete** foundation.

Contains: Corner gussets, perimeter clips, hardware, 1/4" masonry drill bit and installation instruction.

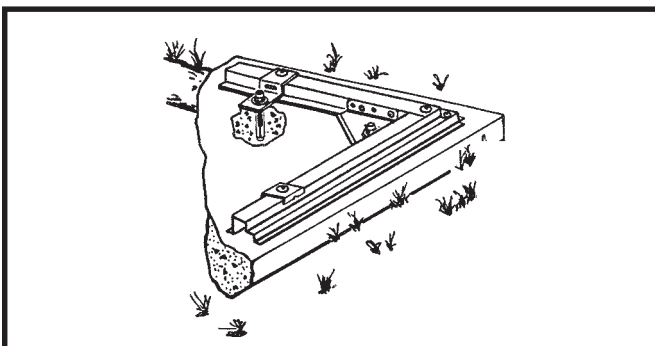

Anchoring into Concrete:

1. For poured concrete slab or footing or patio blocks: Use 1/4" x 2" Lag Screws.
2. For Anchor Post of Concrete poured after building is erected: Use 1/4" x 6" Lag Screws.

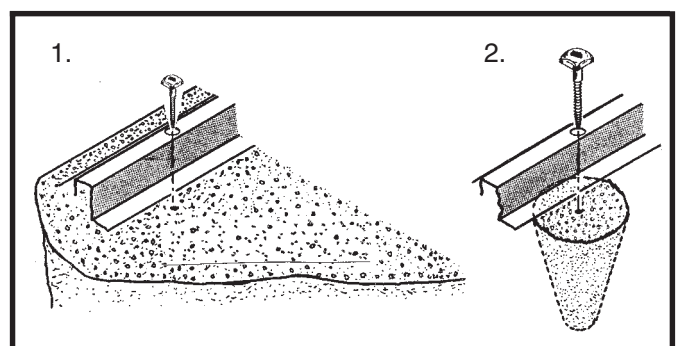

Hardware

BI11

Remove from bag of screws
and save for the last step



65103
#8-32 Hex Nut (31)



65900A
#10Bx1/2" Black Screw (4)
(Packed with Screws)



65923
#8-32x3/8" Bolt (31)



65004
#8Ax5/16" Screw (121)

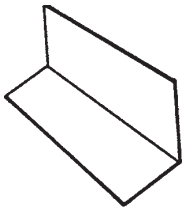

66082
Corner Cap (2)

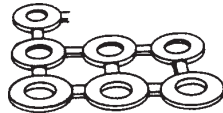

66646
Washer (137)
(4 sheets of 40)



65109
#8-32 Acorn Nut (3)
(Packed with Screws)



66098
Plastic Spacer (2)
(Packed with Screws)



66769
Door Slide (2)

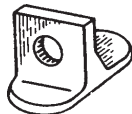

66382
Lower Door Guide (2)

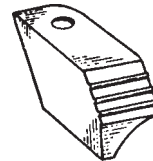

66183
Roof Trim Cap
(2 right & 2 left)

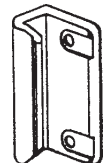

66260
Handle (1)

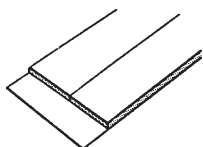

67236
Adhesive Pad (2)

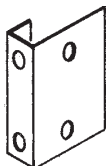

7972
Door Handle Lock Bracket (1)



66029
Plug (1)
(Packed with Screws)



65914
#6Ax7/8" Screw (2)
(Packed with Screws)

Parts List

BI12

Assembly Key No.	Part Number	Part Description	Quantity in Carton	Check List
1	3719	Door Handle Brace	1	
2	6300	Vertical Door Brace	1	
3	6627	Wall Panel	1	
4	6633	Corner Panel	2	
5	7044	Corner Panel	2	
6	10500	Horizontal Door Brace	2	
7	10473	Door	1	
8	7461	Rear Wall Angle	1	
9	7464	Right Roof Panel	1	
10	7465	Left Roof Panel	1	
11	7532	Right Gable	1	
12	7533	Left Gable	1	
13	7534	Roof Trim	2	
14	7660	Roof Beam	1	
15	7661	Header	1	
16	9698	Door Jamb	1	
17	9918	Rear Wall Channel	1	
18	9919	Side Wall Channel	2	
19	8971	Side Floor Frame	2	
20	8972	Rear Floor Frame	1	
21	9370	Door Jamb	1	
22	9456	Front Wall Panel	1	
23	9457	Door Track	1	
24	9458	Front Floor Frame	1	

Assembly by Key No.

B113

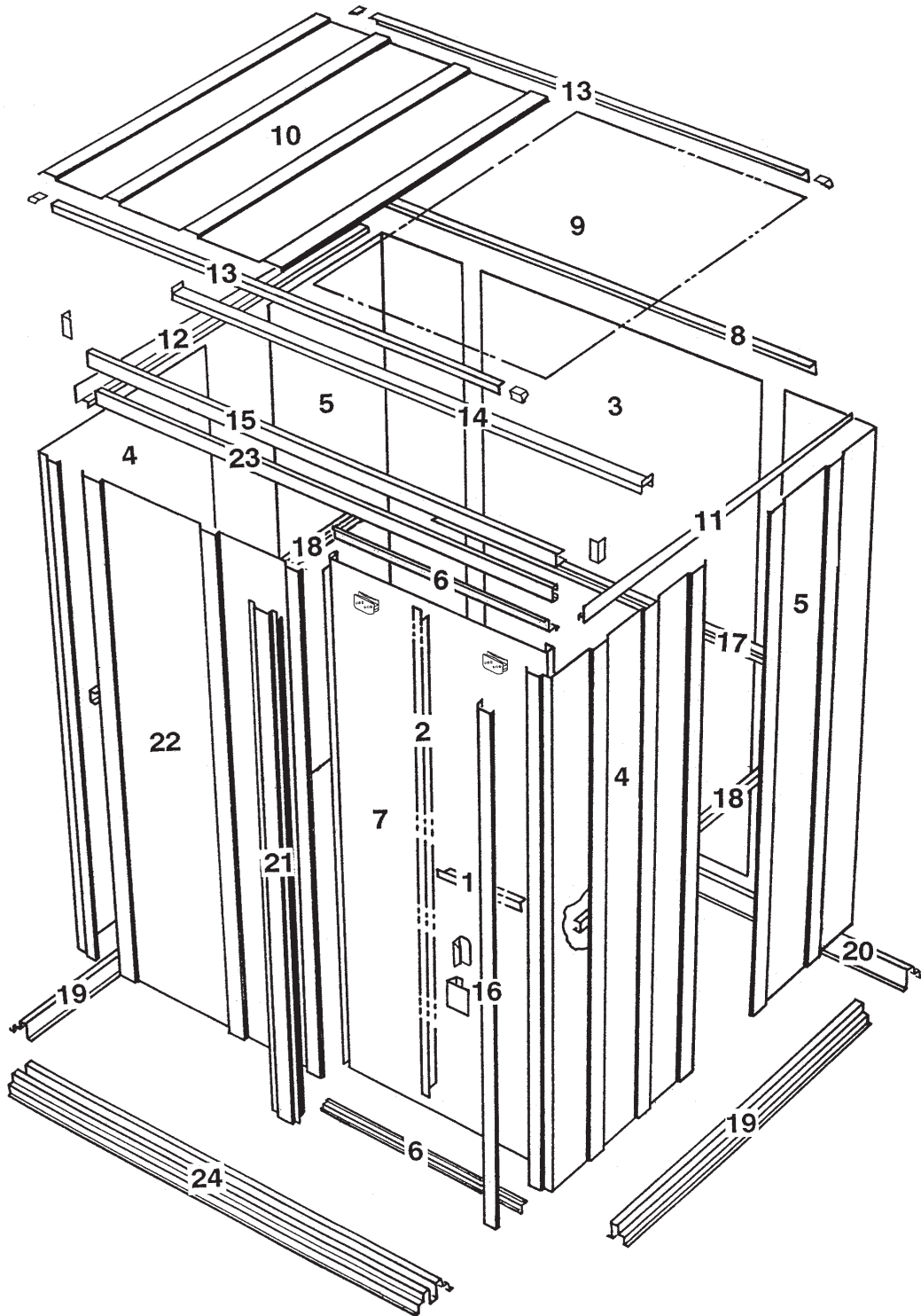

Step 1

BI14

● Parts Needed For ● Door Track/Header Assembly

- 9457 Door Track (1)
- 7661 Header (1)

The door track/header assembly supports the sliding door and reinforces the front wall. It is made up of two pieces.

1 Using the **door track**, with *small holes on top*, join the **header**, *short leg on top*, as shown using screws.

2 Position **door slides** onto the legs, from the end of door track, as shown in the end view.

3 Set this piece aside for later use.

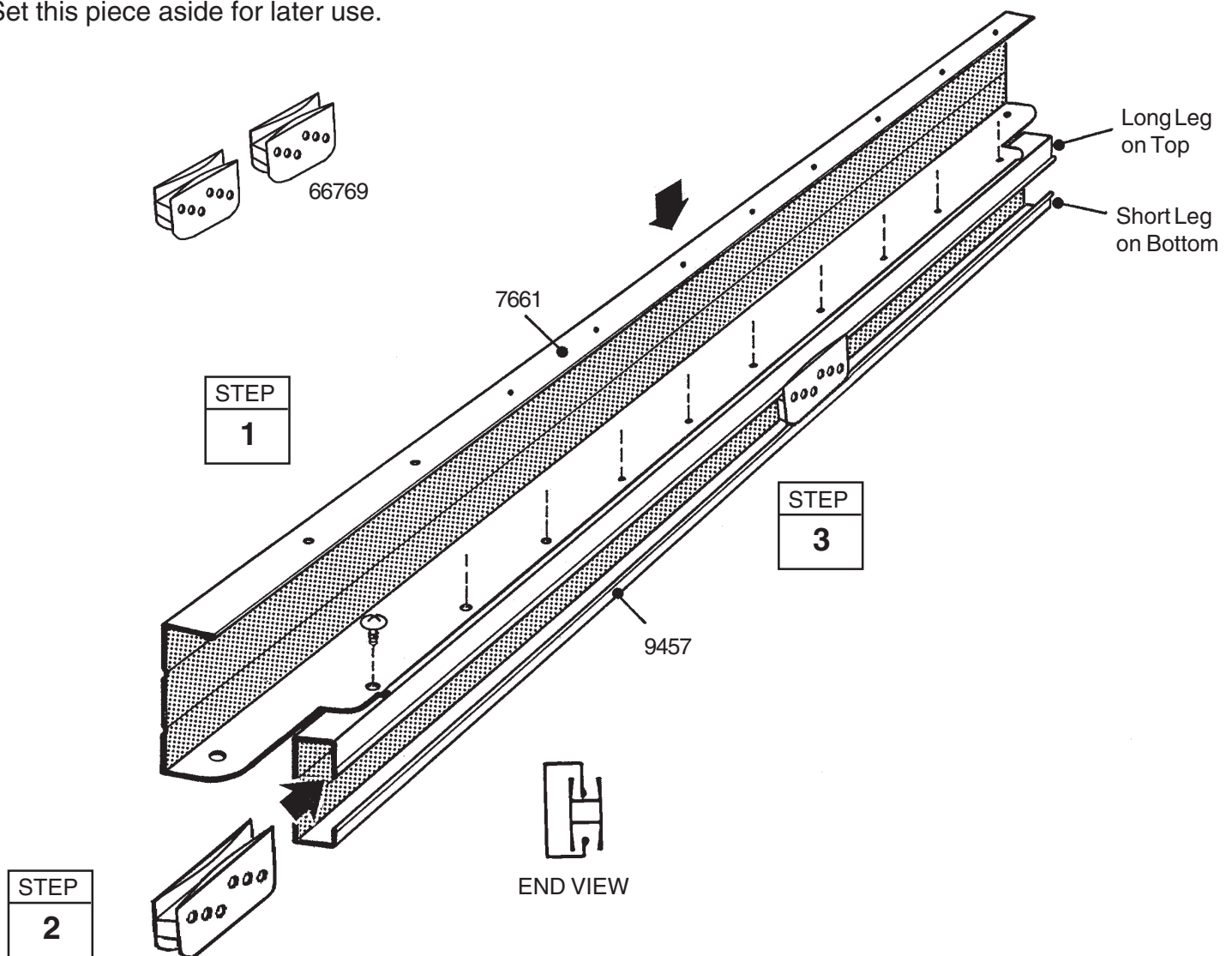

Step 2

B115

● Parts Needed For ● Floor Frame

- 9458 Front Floor Frame (1)
- 8972 Rear Floor Frame (1)
- 8971 Side Floor Frame (2)

1 Assemble the four corners of the floor frame using two screws at each corner as shown. At the front corners fasten bolts through from the bottom with nuts on top.

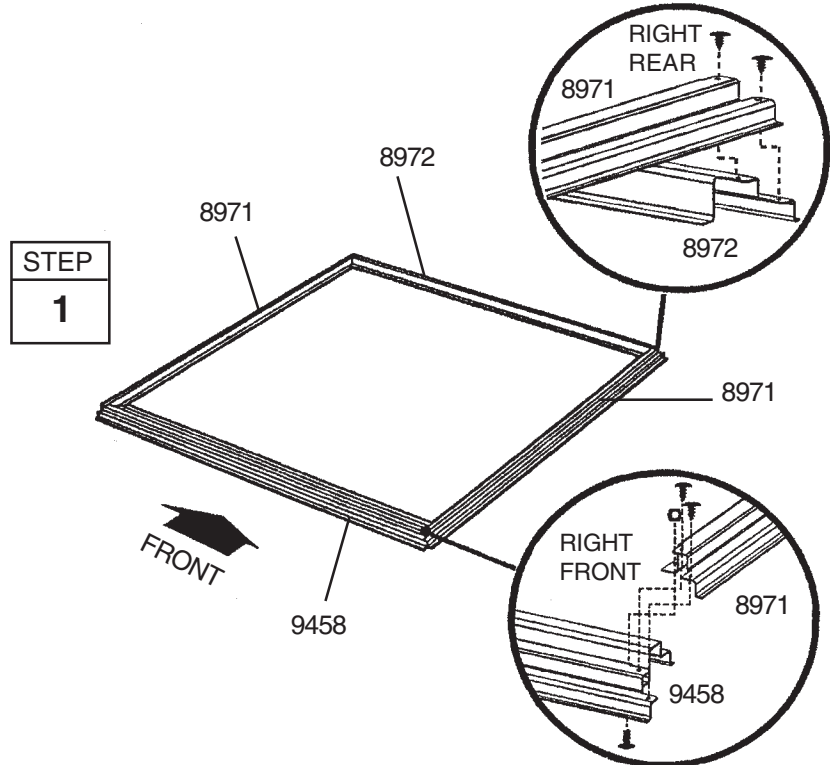

2 Measure the floor frame diagonally. When the diagonal measurements are equal, the floor frame is square.

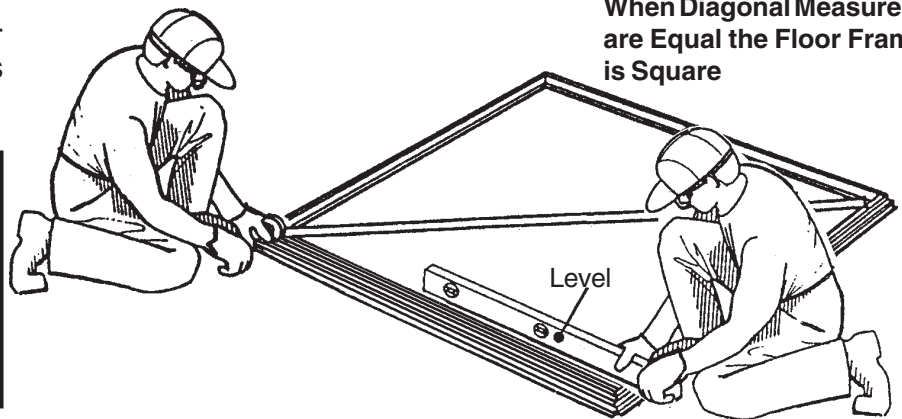

NOTE

If using a wood platform or concrete slab do not fasten the floor frames to your base at this time. You will anchor the building after it is erected.

NOTE

If you have purchased a Floor Frame Kit you need to install it at this time.

The floor frame *must* be square and level or holes will not align.

Step 3

BI16

● Parts Needed For ● Corners

- 7044 Corner Wall Panel (2)
- 6633 Corner Wall Panel (2)

NOTE

The remainder of the building assembly requires many hours and more than one person. Do not continue beyond this point if you do not have enough time to complete the assembly today. A partially assembled building can be severely damaged by light winds.

Each screw and bolt in the wall requires a washer.

1 Position rear **corner panels** at the corners of the floor frame as shown. The widest part of each corner panel must be placed along side of the building. Fasten corner panels to the floor frame using four screws.

Support the corner panel with a step ladder until overlap is fastened.

2 Attach the front **corner panels** to the front corners, as shown. The crimped rib should go under the rib of the adjacent panel. Fasten overlapping rib using 2 screws and a bolt with nut.

NOTE

Be careful to install the correct panel in each position as shown.

3 Double-check the part numbers of the corner wall panels, before proceeding.

The floor frame *must be square and level* or holes will not align.

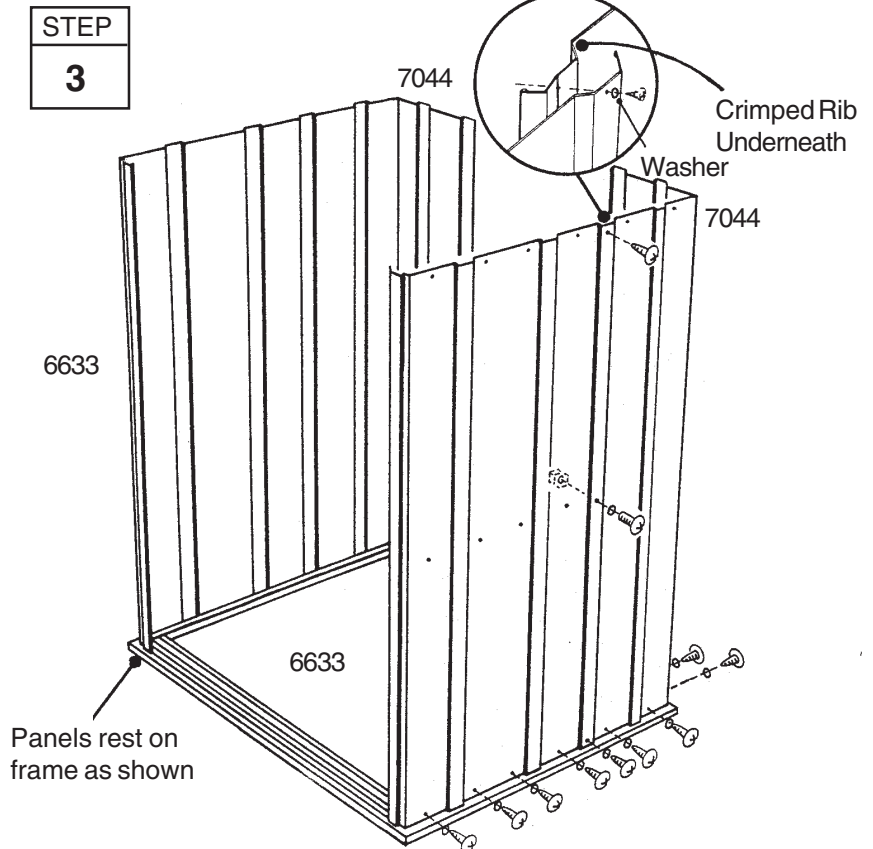
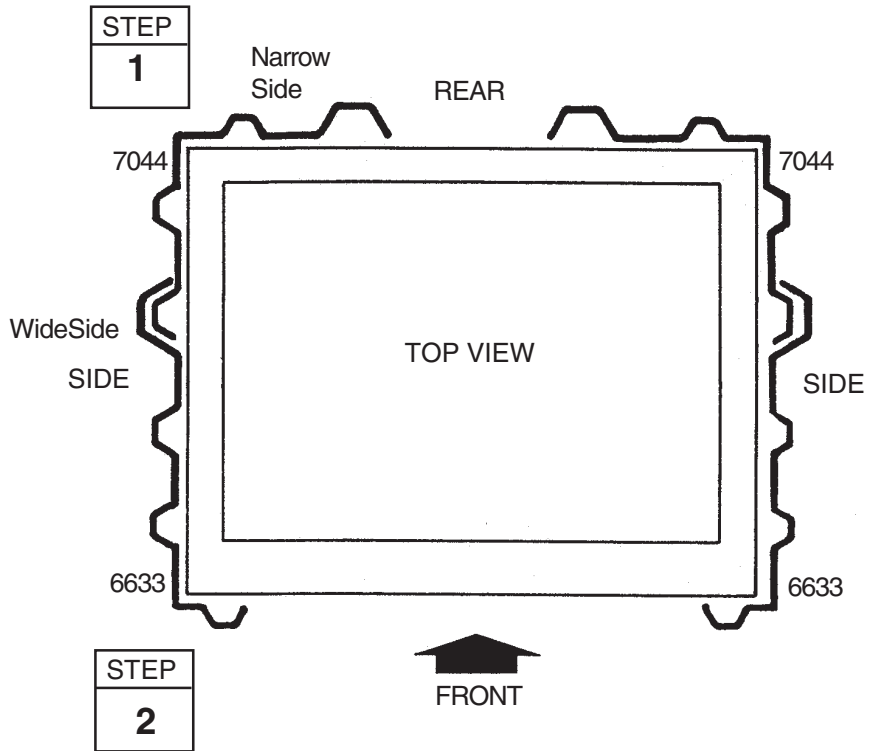

Step 4

BI17

● Parts Needed For ● Frames

- 7461 Rear Wall Angle (1)
- 9918 Rear Wall Channel (1)
- 9919 Side Wall Channel (2)

The main frame pieces give rigidity to the side and rear walls and provide a surface for attaching the gables which support the roof.

1 Fasten the **rear wall angle** across the top of the rear wall using screws.

2 Fasten the **rear wall channel** across the middle of the rear wall using screws.

3 Fasten the **side wall channels** across the middle of the side panels using screws. Fasten overlaps in rear corners with bolts and nuts.

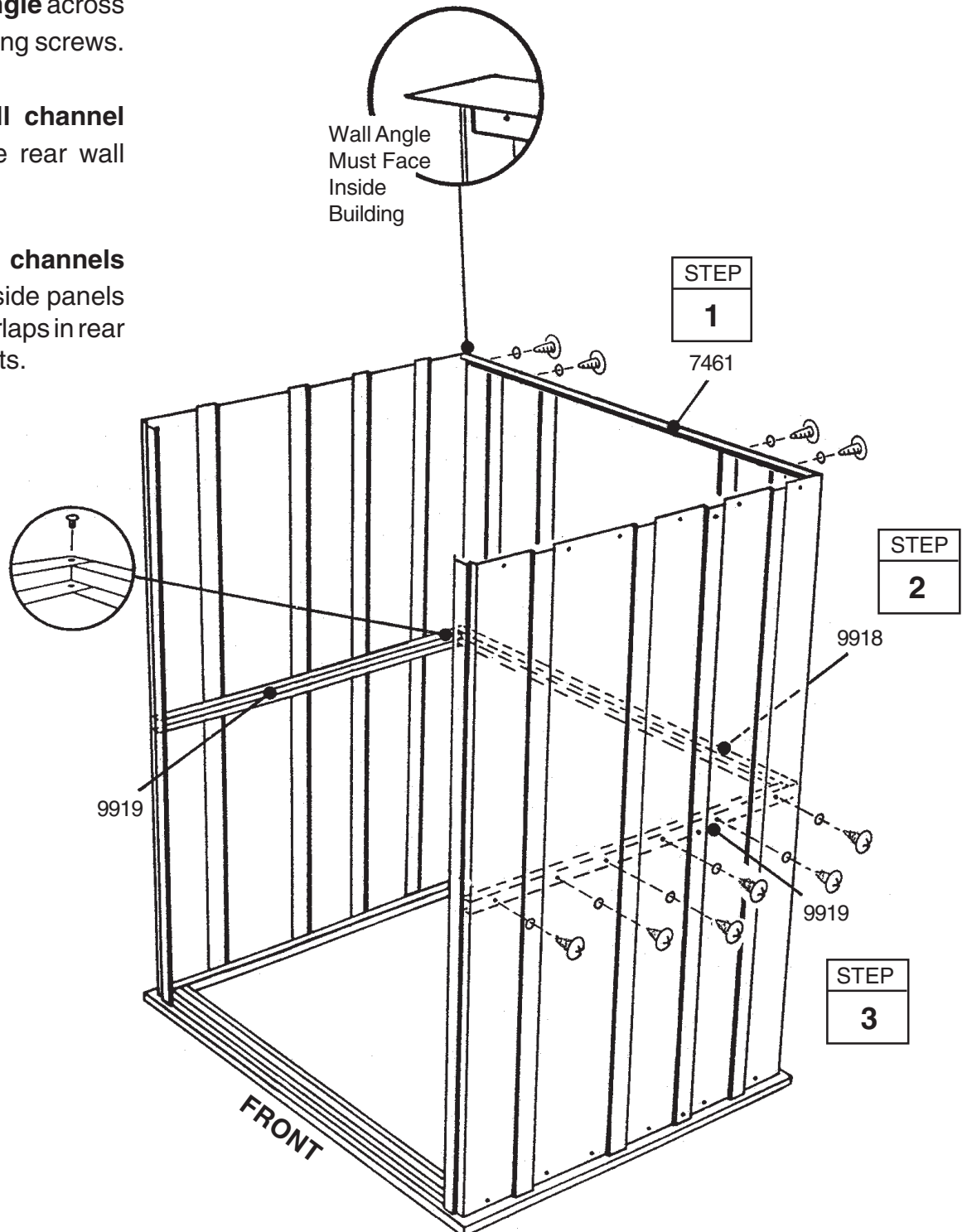

Step 5

BI18

● Parts Needed For ● Panels/Track/Jambs

- 9456 Front Wall Panel (1)
- Door Track Assembly (1)
- 9698 Door Jamb (1)
- 9370 Door Jamb (1)
- 6627 Wall Panel (1)

Each wall panel has a crimped rib on one side. The crimped rib should go under the rib of the adjacent panel. The door jambs reinforce the door opening and provide an attractive trim.

1 Fasten the **front wall panel** to the left front corner, as shown. Fasten overlapping rib as before.

2 Fasten the **door track/header assembly** across the top of the front wall panel using screws. See the figure.

3 Fasten the center of the right **door jamb** to the right corner panel with a bolt and nut. Fasten the top of the jamb to the door track with a 7/8" screw and a plastic spacer, as shown. Do the same for the bottom.

4 Fasten a left **door jamb** to the front panel with three bolts, nuts and acorn nuts, as shown. Push a **plug** into hole at center of jamb, closest to door opening. Fasten the top of the jamb to the door track with two screws. Do the same for the bottom into frame.

5 Fasten **wall panel** to the rear of building, as before.

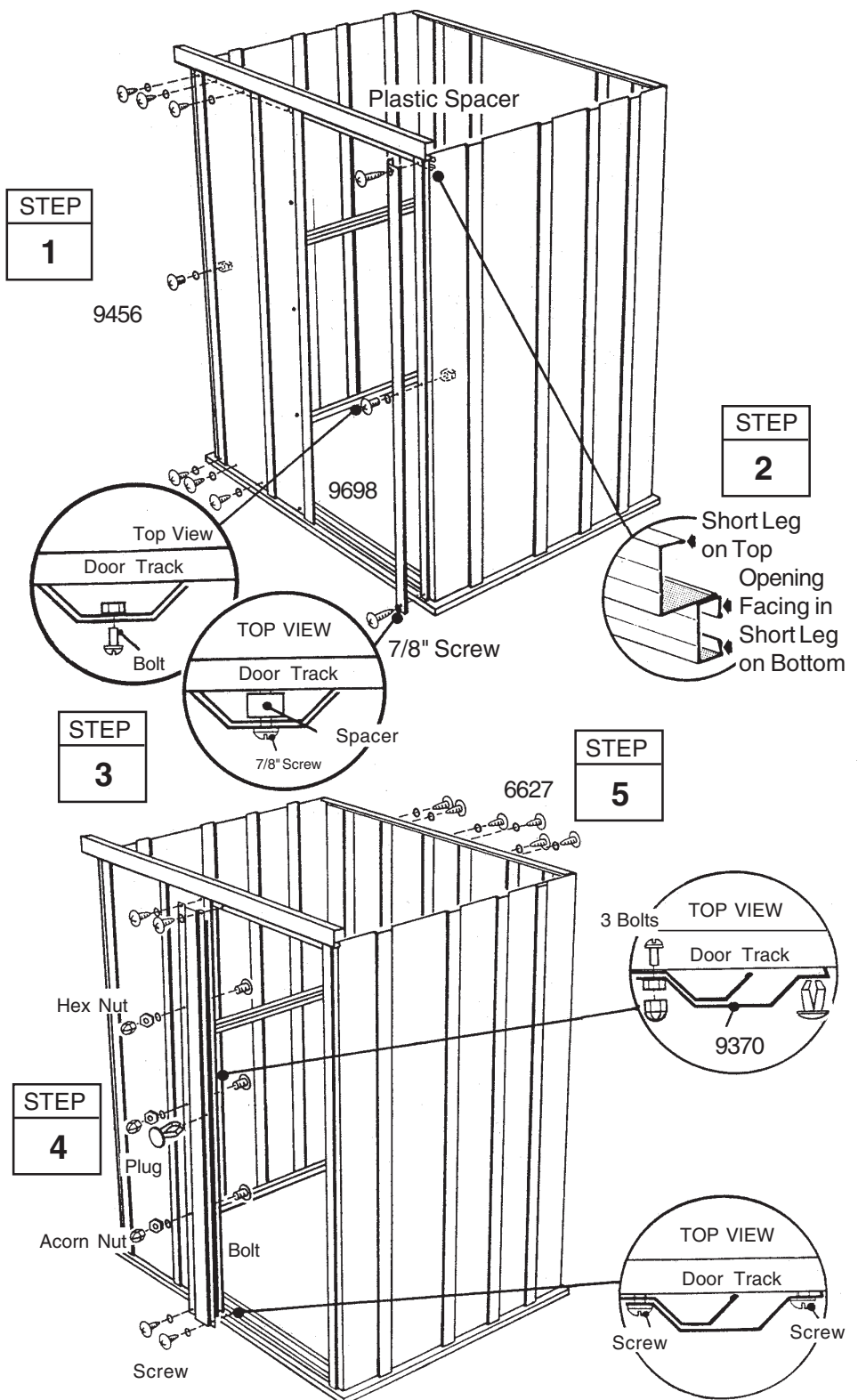

Step 6

B119

● Parts Needed For ● Gables/Roof Beam

- 7532 Right Gable (1)
- 7533 Left Gable (1)
- 7660 Roof Beam (1)

1 Lift and fasten a **right** and **left gable**, overlapping header in front, to the right and left hand wall with screws. Join gables to header in the front corners, using a bolt and nut.

2 Bend tab at each end of **roof beam** upward. Position beam across width of building, down on the ledge of gables at center hole location.

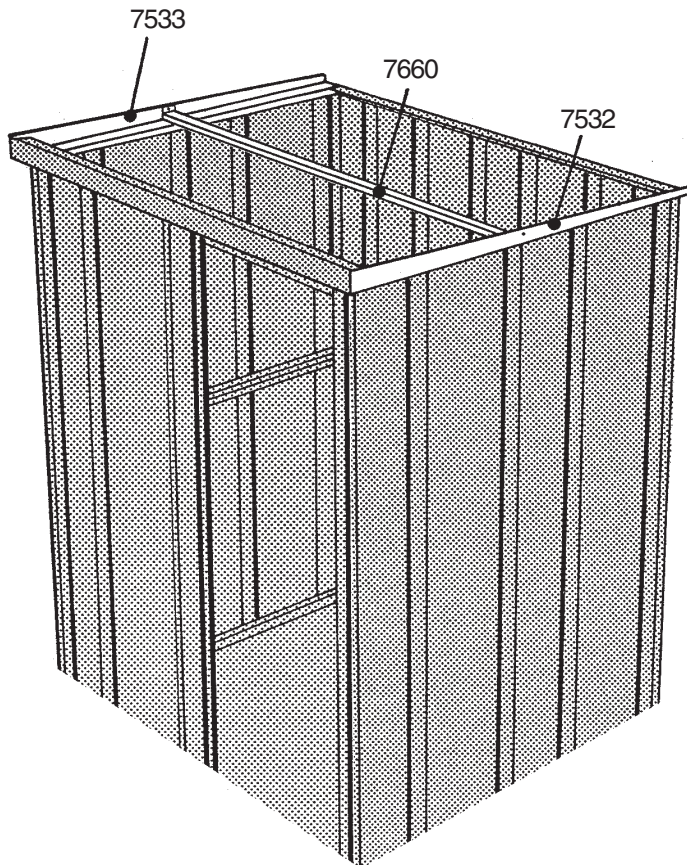
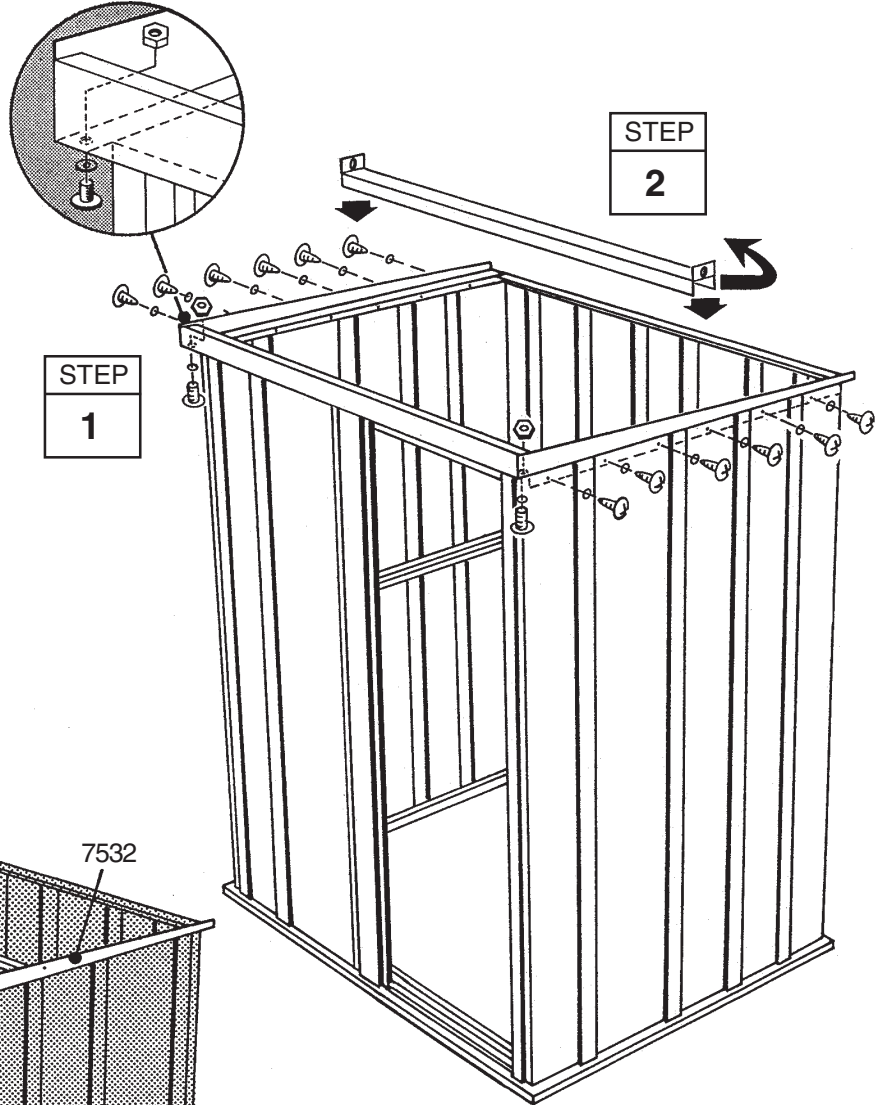

Step 7

B120

● Parts Needed For ● Roof Assembly

- 7464 Right Roof Panel (1)
- 7465 Left Roof Panel (1)

Installing the roof panels is best done with a step ladder. Begin installing roof panels at the right side of the building. Each screw and bolt in the roof requires a washer.

NOTE

Measure the building diagonally again and make adjustments to make sure the building is square. This will make the roof panels fit better, and holes will align.

1 Locate the roof panels by their numbers and place them on the ground alongside the building in their proper positions.

2 Position a **right roof panel** at the right side and fasten to the gable and header using screws and bolts as shown. *Do not fasten the lower end of the panels to the rear wall angle until both panels are in place.*

Note: Tab of roof beam is fastened between roof panel and gable using the center hole.

3 Install the **left roof panel** on the left side in the position shown above. Fasten at overlap with a bolt.

4 Fasten the lower end of the panels to the rear wall angle using screws.

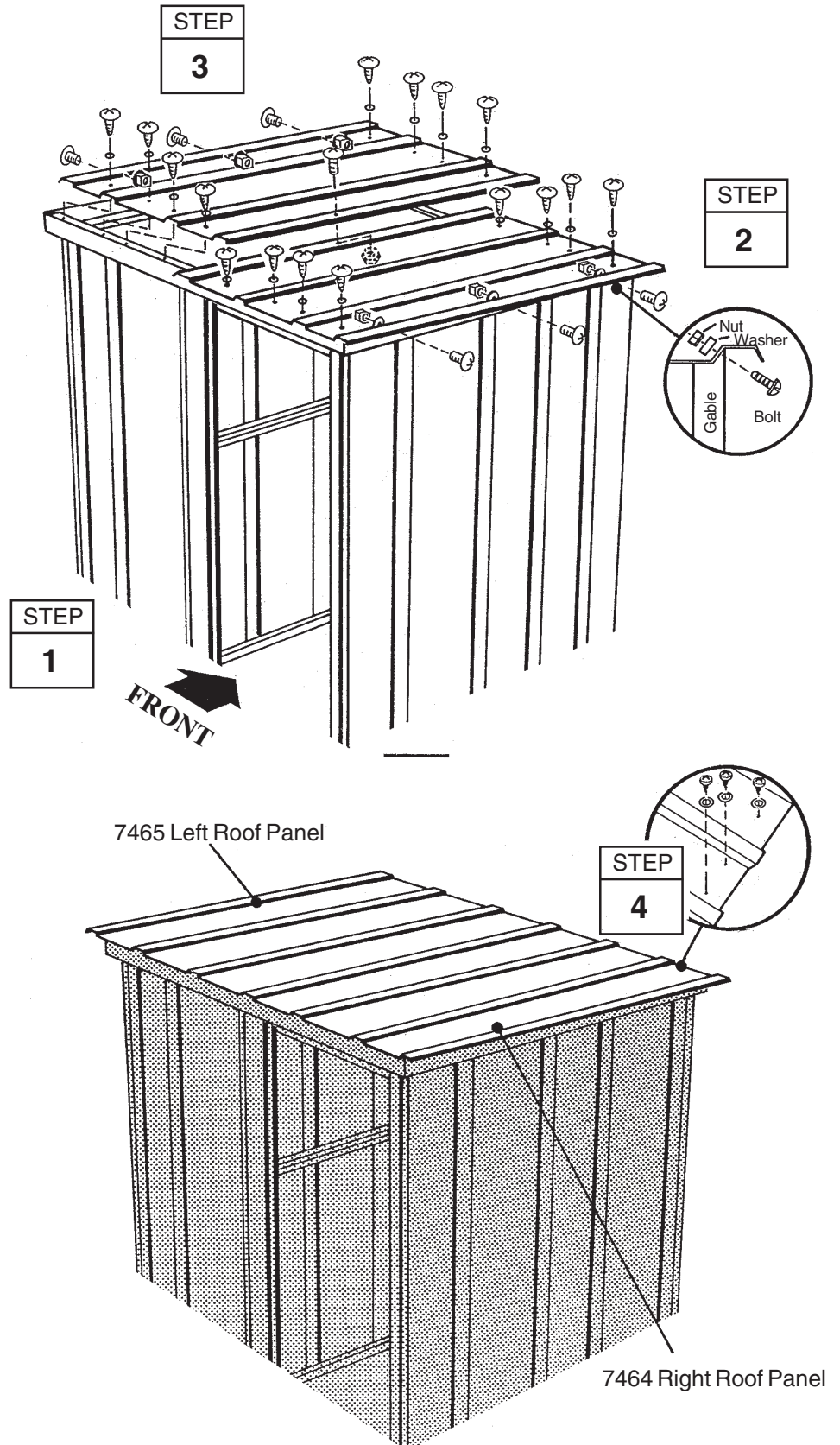

Step 8

BI21

● Parts Needed For ● Roof Trim

● 7534 Roof Trim (2)

1 Attach the **roof trim** to the ends of the roof panels on each side of the building using screws at each panel overlap.

2 Using your thumb and index finger, overbend the bottom flange of the roof trim at the corner inward enough so the right and left roof trim caps fit onto right and left corners.

3 Fasten the roof trim caps to the roof trim using a screw.

4 Fasten the **corner caps** to the ends of the header, using adhesive pads.

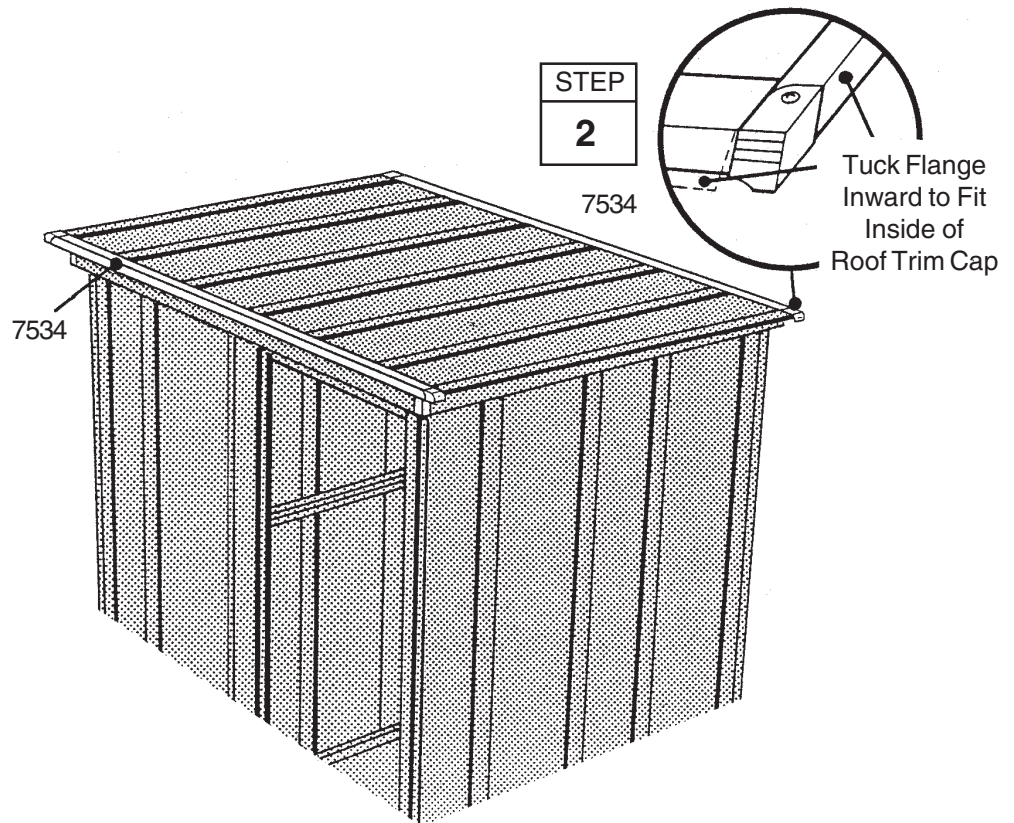
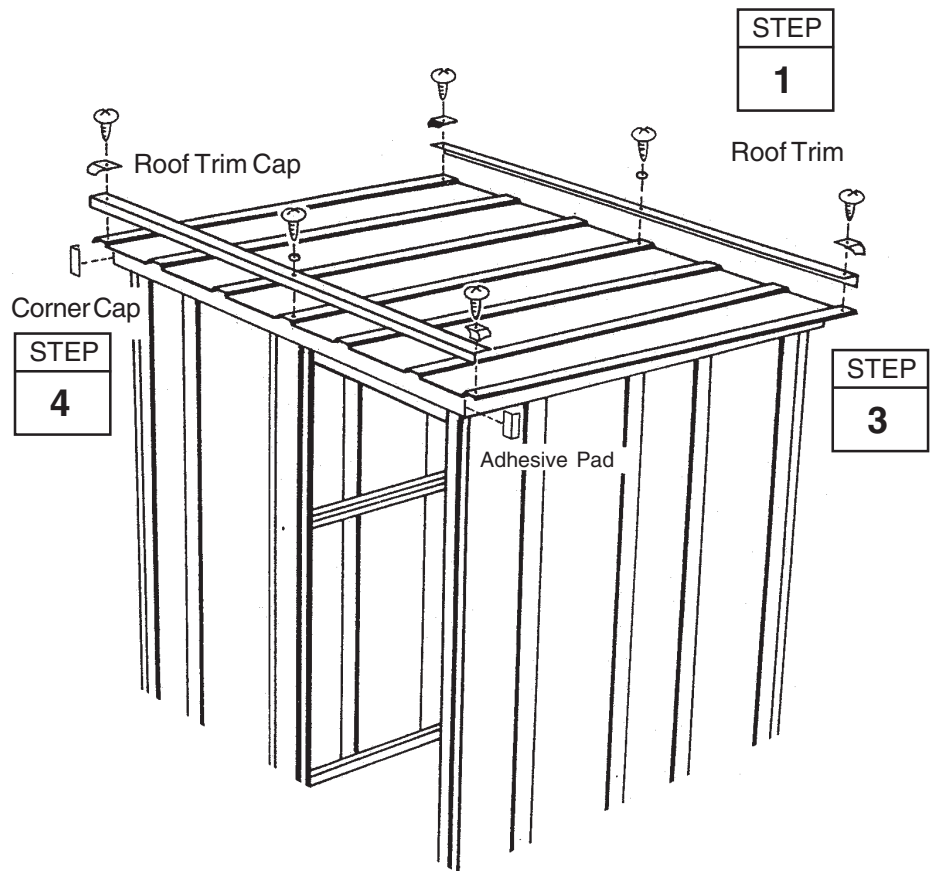

Step 9

BI22

● Parts Needed For ● Door Assembly

- 3719 Door Handle Brace (1)
- 10473 Door (1)
- 10500 Horizontal Door Brace (2)
- 6300 Vertical Door Brace (1)

The steps on this page tell how to assemble the door. Each bolt and screw in the door requires a washer. Proceed as follows:

1 Attach the **door handle brace** and **handle** to the **door** with 1 bolt as shown. *Don't tighten the bolt yet.*

2 Swing the door handle brace up to the hole in the center of the door and insert a screw.

3 Hold the **vertical door brace** against the center of the inside surface of the door and turn the screw to hold the vertical door brace and door handle brace in place. Fasten to door above and below center connection using 2 screws.

4 Insert a second bolt in the door handle and tighten both bolts.

5 Put a **horizontal door brace** onto the top edge *and* bottom edge and fasten *with 1 bolt in the center*.

6 Attach the **lower door guides and bolts** as shown.

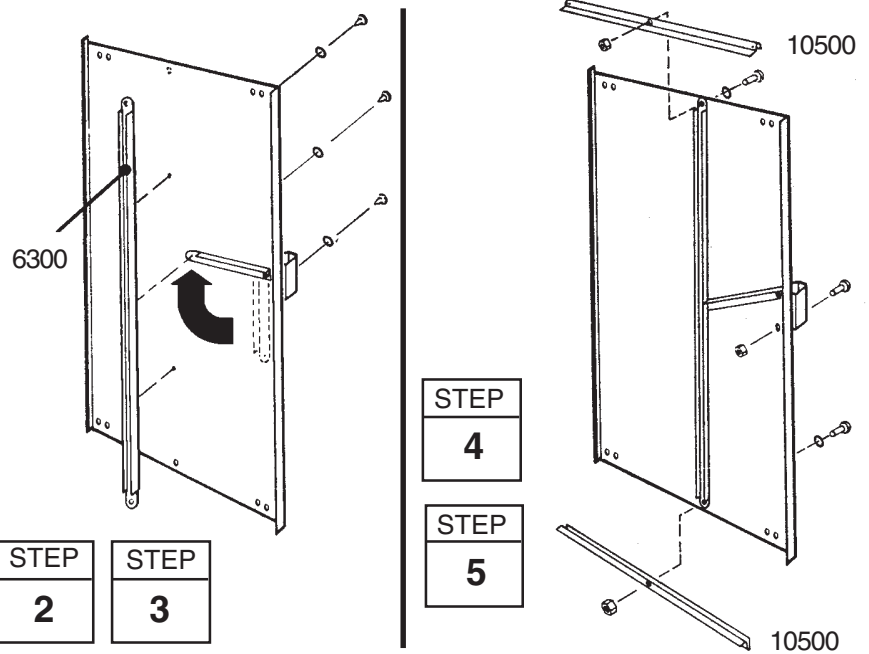
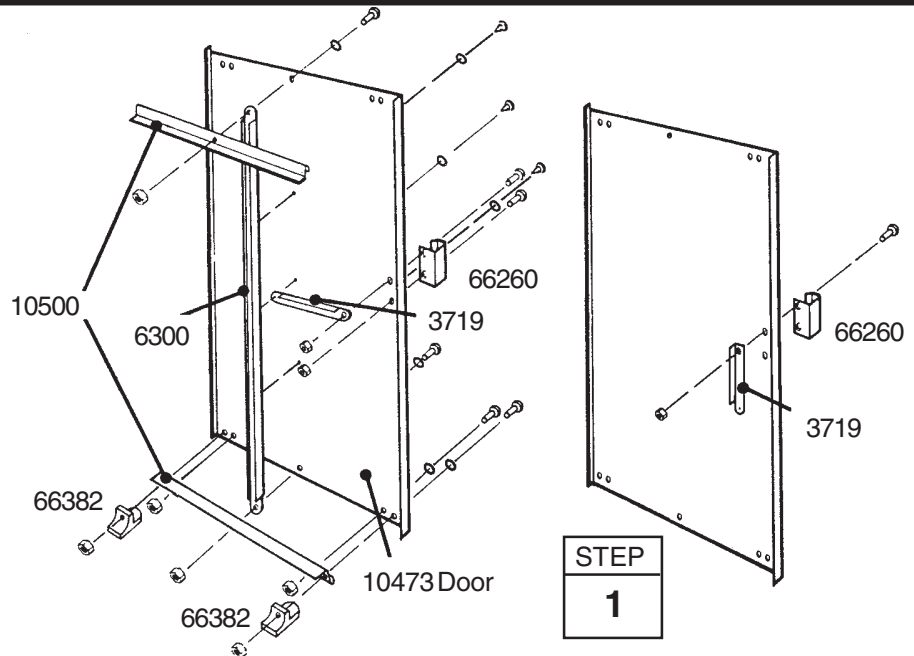

END VIEW
SHOWING:

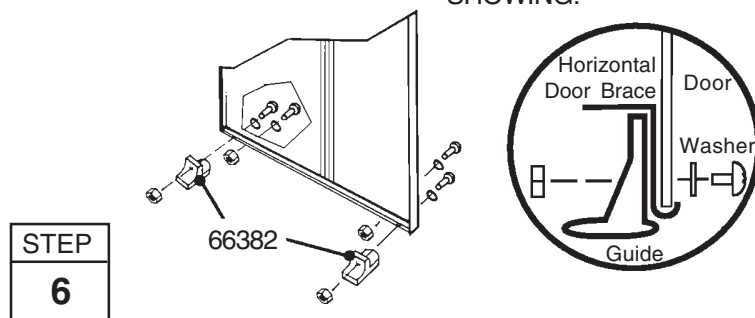

Step 10

B123

● Parts Needed For ● Door Installation & Adjustment

- Door Assembly (1)
- 7972 Door Handle Lock Bracket (1)

1 From inside the building, put the bottom of the door assembly (on your right when you are inside the building) behind door jamb into the front frame track.

2 Position the top of the door so that the holes in the door line up with the holes in the door slides.

3 Fasten the door to the door slides using two #10Bx1/2" screws per door slide.

NOTE

The holes in the door slides allow you to adjust the door. Place the door in the middle holes.

4 Attach **door handle lock bracket** to right hand door jamb using two bolts and nuts.

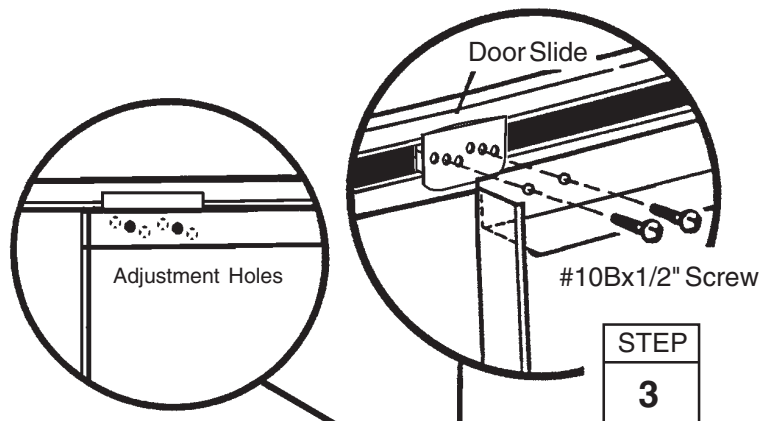
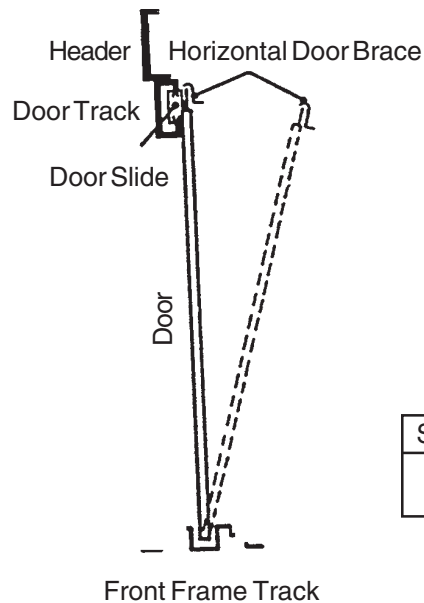

Adjustment Holes Allow Door to Meet Jamb Evenly Along Its Length

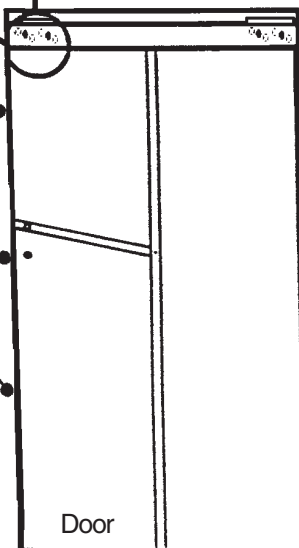
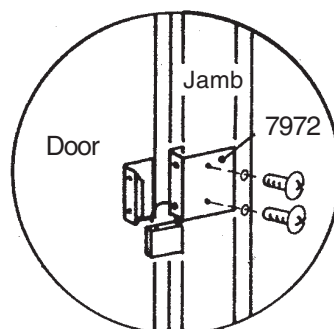

Keep this Owner's Manual and Assembly Instructions for future reference.

BW54-A

BWW54

BWG54

YL54

YL54M

BI24

SOME FACTS ABOUT RUST

Rusting is a natural oxidizing process that occurs when bare metal is exposed to moisture. Problem areas include screw holes, unfinished edges, or where scrapes and nicks occur in the protective coating through normal assembly, handling and use. Identifying these natural rusting problem areas and taking some simple rust protection precautions can help to stop rust from developing, or stop it quickly as soon as it appears.

1. Avoid nicking or scraping the coating surface, inside and out.
2. Use all the washers supplied. In addition to protecting against weather infiltration, the washers protect the metal from being scraped by the screws.
3. Keep roof, base perimeter and door tracks free of debris and leaves which may accumulate and retain moisture. These can do double damage since they give off acid as they decay.
4. Touch up scrapes or nicks and any area of visible rust as soon as possible. Make sure the surface is free of moisture, oils, dirt or grime and then apply an even film of high quality touch-up paint.